

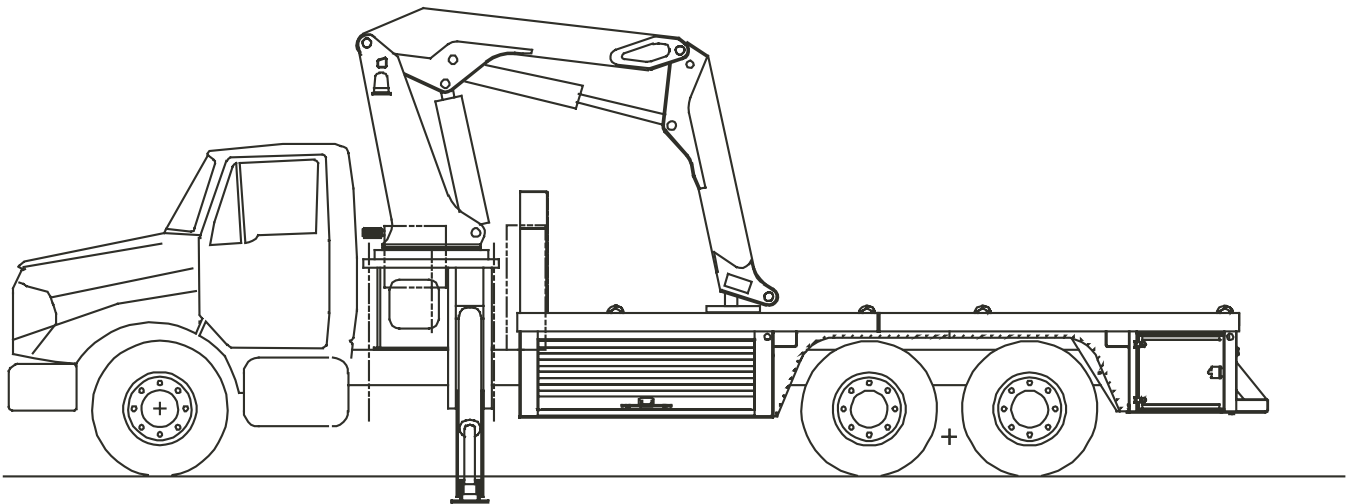

Model 23516 Crane

Volume 2 - PARTS AND SPECIFICATIONS

- Section 1 SPECIFICATIONS**
- Section 2 CRANE REFERENCE**
- Section 3 REPLACEMENT PARTS**
- Section 4 GENERAL REFERENCE**



IOWA MOLD TOOLING CO., INC.

BOX 189, GARNER, IA 50438-0189

TEL: 641-923-3711

MANUAL PART NUMBER 99903471

Iowa Mold Tooling Co., Inc. is an Oshkosh Truck Corporation company.

REVISIONS LIST

DATE	LOCATION	DESCRIPTION OF CHANGE
-	-	-
20010530	3-47	ADDED 99903201 WIRING SCHEMATIC
20010703	3-9	#14 - 60122821 WAS 60120168
20020117	3-35	#3 - CORRECT QTY IS 8
20020311	3-11,22,23,26,27,39, 40,46	ECN 8877 - WEAR PAD CHANGES THAT AFFECTED VARIOUS PARTS
20020416	3-49	ECN 8903 - ADDED 99903160 TO MANUAL
20020520	1-3,4,5,7 3-11,36,38	ADDED NEW IMT LOGO, EDITED UNITS ON SPECIFICATIONS, UPDATED CAP PLAC
20020826	1-3,4,7,8,11,12 2-6 3-11	ECN 8921 - ADDED OIL RECOMMENDATIONS, EDITED DRAWINGS & BOM'S EDITED UNITS ON SPECIFICATIONS, CP UPDATED PM KIT
20021112	Throughout	CHANGED PART DESCRIPTION ON #8, 60124267, TO SWIVEL LINK FROM SWIVEL HOOK Split Comm-IV package into components - released 23516 crane manual.\
20030327	1-6	UPDATED RBM, FRAME YIELD STRENGTH ON MIN. CHASSIS SPECIFICATIONS.
20030417	3-13,14	ADDED GEAR BOX DWG, BOM - 70056564
20030605	3-28 3-43	ECN 9173 - CHANGED TO QUICK CHANGE MODEL - DECAL KIT REVISIONS ADDED GEARBOX DRAWING
20030801	3-6,8,10 3-34-40	ECN 9206 - MISC CHANGES TO BOOM ASSEMBLIES ECN 9198 - ELECTRICAL IMPROVEMENTS
20030825	3-31-35	CORRECTED ERROR IN 14K160TH SERIAL NUMBER
20031216	3-16	ECN 9333 - ADDED SPRING TO 99901235 HYDRAULIC KIT-RESERVOIR
20040503	3-11,37	ECN 9411 - ADDED ELEC. CONTRL DECAL 70396515 TO ELEC. BOX 41718269 ECN 9420 - UPDATED 3D295990 CYLINDER TO DUAL HOLDING VALVES
20040610	3-31,34	ECN 9428 - CHANGED FROM CIRCUIT BREAKERS TO MAXI-FUSES ON 99903201 & 99903357
20050627	THROUGHOUT SECT.3	ECN 9688 - CHANGE TO PIN & GREASE EXTENSION FOR ROTATOR DRIVE BEARINGS
20050712	3-27	ECN 9782-1 - CHANGE TO CLAMP PLATE ON 93715476
20051215	3-11	ADDED HOOK PART NUMBER TO 41815834 DRAWING
20060206	3-21	ECN 10053 - REV G 99903152
20060714	3-2,5,11,20	ECN 10181 - ASSEMBLY IMPROVEMENTS ON 99903151, 41715808, 3D295990
20061020	1-1	UPDATED OWNERSHIP STATEMENT.

INTRODUCTION

This volume deals with information applicable to your particular crane. For operating, maintenance and repair instructions, refer to Volume 1, OPERATION, MAINTENANCE AND REPAIR.

We recommend that this volume be kept in a safe place in the office.

This manual is provided to assist you with ordering parts for your IMT truck-mounted articulating crane. It also contains additional instructions regarding your particular installation.

It is the user's responsibility to maintain and operate this unit in a manner that will result in the safest working conditions possible.

Warranty of this unit will be void on any part of the unit subjected to misuse due to overloading, abuse, lack of maintenance and unauthorized modifications. No warranty - verbal, written or implied - other than the official, published IMT new machinery and equipment warranty will be valid with this unit.

In addition, it is also the user's responsibility to be aware of existing Federal, State and Local codes and regulations governing the safe use and maintenance of this unit. Listed below is a publication that the user should thoroughly read and understand.

ANSI/ASME B30.22
MOBILE AND LOCOMOTIVE CRANES
The American Society of Mechanical Engineers
United Engineering Center
345 East 47th Street
New York, NY 10017

Three means are used throughout this manual to gain the attention of personnel. They are NOTE's, CAUTION's and WARNING's and are defined as follows:

NOTE

A NOTE is used to either convey additional information or to provide further emphasis for a previous point.

CAUTION

A CAUTION is used when there is the very strong possibility of damage to the equipment or premature equipment failure.

WARNING

A WARNING is used when there is the potential for personal injury or death.

Treat this equipment with respect and service it regularly. These two things can add up to a safer working environment.

**Read and familiarize yourself with the
IMT OPERATOR'S CRANE SAFETY MANUAL
before operating or performing any maintenance
on your crane.**

SECTION 1. 23516 CRANE SPECIFICATIONS

MODEL 23516 CRANE SPECIFICATIONS	2
PERFORMANCE CHARACTERISTICS	3
POWER SOURCE	3
CYLINDER HOLDING VALVES	3
EXCESSIVE LOAD LIMIT SYSTEM (ELLS)	3
ROTATION SYSTEM	3
HYDRAULIC SYSTEM.....	3
23516 CRANE CAPACITY CHART	4
GEOMETRIC CONFIGURATION-CRANE	5
STOWED POSITION	5
MINIMUM CHASSIS SPECIFICATIONS FOR 23516	6

MODEL 23516 CRANE SPECIFICATIONS

GENERAL SPECIFICATIONS

	DOMESTIC UNITS	METRIC UNITS
CRANE RATING	235,000 ft-lb	32.5 ton-meter
REACH - From Centerline of Rotation	16'-0"	4.88 m
HYDRAULIC EXTENSION(S)	36"	91.44 cm
LIFTING HEIGHT -From Mounting Surface of Crane	23'-9"	7.24 m
WEIGHT OF CRANE	11,720 lb	5316 kg
OUTRIGGER SPAN - Crane Side from Centerline of Chassis	18'-0"	5.49 m
STOWED HEIGHT - Crane Only from Mounting Surface (Based on 41" frame height)	12'-11"	3.94 m
MOUNTING SPACE REQUIRED - Crane Base	52" x 52"	132 cm x 132 cm
HORIZONTAL CENTER OF GRAVITY - - From Centerline of Rotation with Crane in Stored Position	23"	58.42 cm
OPTIMUM PUMP CAPACITY - PTO	16 U.S. GPM @ 3000 psi	60.6 lpm @ 207 bar
OIL RESERVOIR CAPACITY	40 U.S. Gallons	151.4 liters
SYSTEM PRESSURE	3000 psi	207 bar
CONTROLS	Wireless Remote & Manual Handles	Wireless Remote & Manual Handles
CAPACITY LIMITER	Shutdown	Shutdown
MAIN OUTRIGGERS Span Activation	Fold-over 18'-0" Line of sight	Fold-over 5,486mm Line of sight
INNER BOOM ARTICULATION	-7° to 66°	-7° to 66°
OUTER BOOM ARTICULATION	96°	96°

PERFORMANCE CHARACTERISTICS

INNER BOOM ELEVATION:	-7° to +66°	43 seconds
OUTER BOOM ARTICULATION:	96°	43 seconds
EXTENSION BOOM:	36" (914mm)	26 seconds
OUTRIGGER EXTENSION:	42" (1067mm)	72 seconds

POWER SOURCE

Integral-mounted hydraulic pump and PTO application. Other standard power sources may be utilized - minimum power required is 33 horsepower for the crane.

CYLINDER HOLDING VALVES

The holding sides of all cylinders are equipped with integral-mounted counter-balance valves to prevent sudden cylinder collapse in case of hose or other hydraulic failure. The outrigger cylinders have double pilot operated check valves.

The counter-balance valve serves several functions. First, it is a holding valve. Secondly, it is so constructed that it will control the lowering function and allow that motion to be feathered while under load. Finally, if a hose breaks, the only oil loss will be that in the hose.

EXCESSIVE LOAD LIMIT SYSTEM (ELLS)

Overloading of the crane is limited by the ELLS. This is done by disarming the crane functions which make possible the application of greater than allowable stress to the crane structure and components. Functions controlled by the ELLS are tilt up and outer boom up. To relieve the situation, the operator may set the load down or articulate the Tirehandler in the opposite direction to reduce the loaded condition.

ROTATION SYSTEM

Crane rotation is accomplished through a turntable bearing, powered by a high torque hydraulic motor through a planetary gear box. A spring applied hydraulic release brake is an integral part of each planetary gear box which provides rotational and parking brake action. Total gear reduction is 113:1.

HYDRAULIC SYSTEM

The hydraulic system for the crane is a closed center valvebank with an unloader valve, using a fixed displacement pump, requiring 16 gpm (60.6 lpm) optimum oil flow, at 3000 psi (207 bar). Nine-spool, stack-type control valve, six functions for crane control and three functions for tirehand. System includes hydraulic oil reservoir, return-line filter, control valvebank and all hoses and fittings. Wireless remote control and manual levers are provided for all functions except for the outriggers which utilize manual levers located on their respective sides.

IMT reserves the right to change specifications and design without notice.

Above specifications/characteristics are based on IMT's recommended chassis. Any other chassis applications may alter the characteristics.

All other applications are to be approved by IMT.

23516 CRANE CAPACITY CHART

IOWA MOLD TOOLING CO., INC. ● BOX 189 ● GARNER ● IA ● 50438 ● 641-923-3711

Capacities through geometric range are limited to those shown in horizontal position.



- Loads shown are based on crane structural or hydraulic capability. Before lift is made, stability must be checked per SAE J765A.
- Working loads will be limited to those shown. Deduct the weight of load handling devices.

MODEL 23516 CRANE

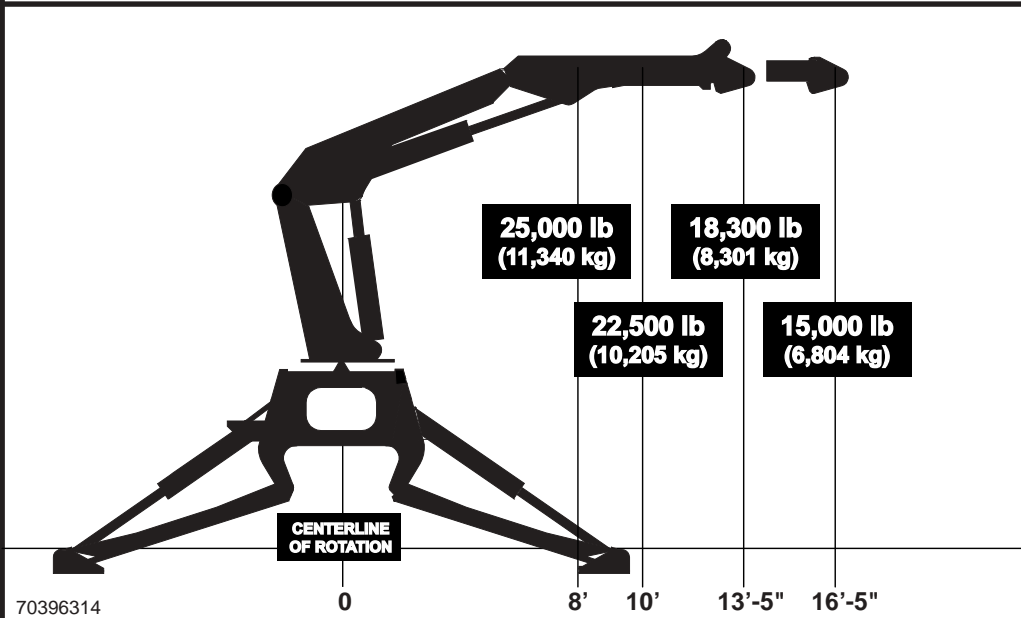
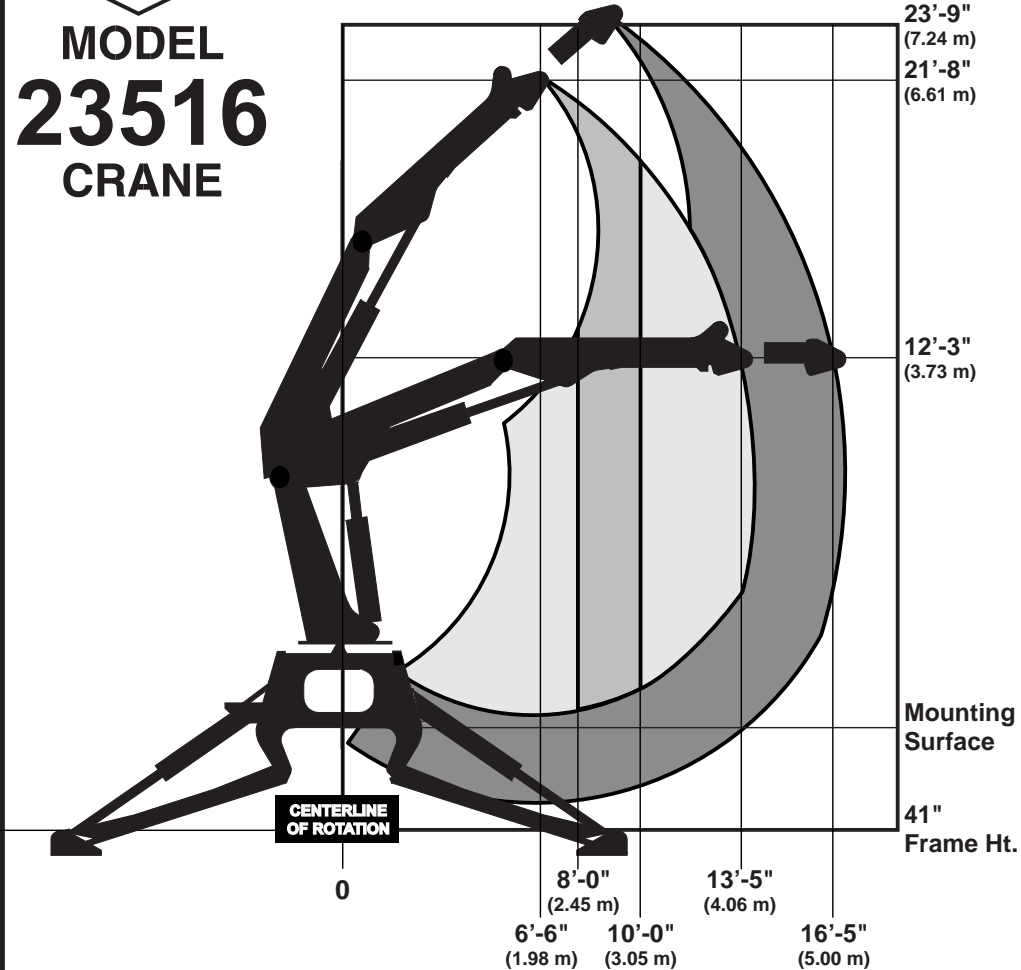

70396314

MINIMUM CHASSIS SPECIFICATIONS FOR 23516

CRANE MOUNT	Behind Cab (<i>Consult factory for rear mount application</i>)	
CRANE WORKING AREA	350°	
CHASSIS STYLE	Conventional Cab	
FRONT AXLE RATING (GAWR)	20,000 lb	9072 kg
REAR AXLE RATING (GAWR)	Tandem Axle (40,000 lb)	18144 kg
**WHEELBASE (Recommended)	256"	650 cm
**CAB-TO-AXLE (Recommended)	192"	488 cm
REQUIRED OUTRIGGER WIDTH	18'-0"	5.49 m
RBM (Recommended)	3,300,000 in-lb	3,797,046 kg-cm
FRAME SECTION MODULUS	30 in ³	491.6 cc
FRAME YIELD STRENGTH	110,000 psi	7734 kg/cm ²
MINIMUM FINISHED UNIT WEIGHT TO MAINTAIN STABILITY		
FRONT AXLE	* 15,700 lb	7121 kg
REAR AXLE	* 23,600 lb	10,705 kg
TOTAL FINISHED UNIT WT.	39,300 lb	17,826 kg

* Allows lifting full capacity load in a 350° arc when crane is installed immediately behind the cab. Great care should be taken when swinging the load from rear of vehicle to front of vehicle since the front axle springs will compress, thus affecting the levelness of the vehicle.

** Base on IMT's recommended chassis. All other applications to be approved by IMT.

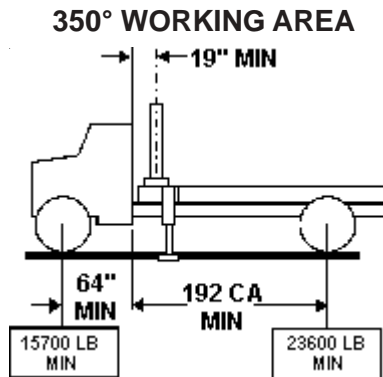

NOTES:

1. GAWR means Gross Axle Weight Rating and is dependent on all components of the vehicle such as axles, tires, wheels, springs, brakes, steering and frame strength meeting the manufacturer's recommendations. Always specify GAWR when purchasing a truck.
2. Minimum axle requirements may increase with use of diesel engines, longer wheelbase or service bodies. Contact the factory for further information.
3. Weight distribution calculations are required to determine final axle loading.
4. All chassis and crane combinations must be stability tested to ensure stability per ANSI B30.22.

SECTION 2. 23516 REFERENCE

**MAJOR CRANE/TIREHAND ASSEMBLIES
& WELDMENT PART NUMBER LOCATIONS 3**

GREASE ZERK LOCATIONS & LUBRICANT REQUIREMENTS 3

RECOMMENDED SPARE PARTS LIST 4

CRANE MOUNTING 5

HYDRAULIC INSTALLATION 6

MAJOR CRANE/TIREHAND ASSEMBLIES & WELDMENT PART NUMBER LOCATIONS

NOTE:

----- indicates location of weldment part numbers for crane assemblies.

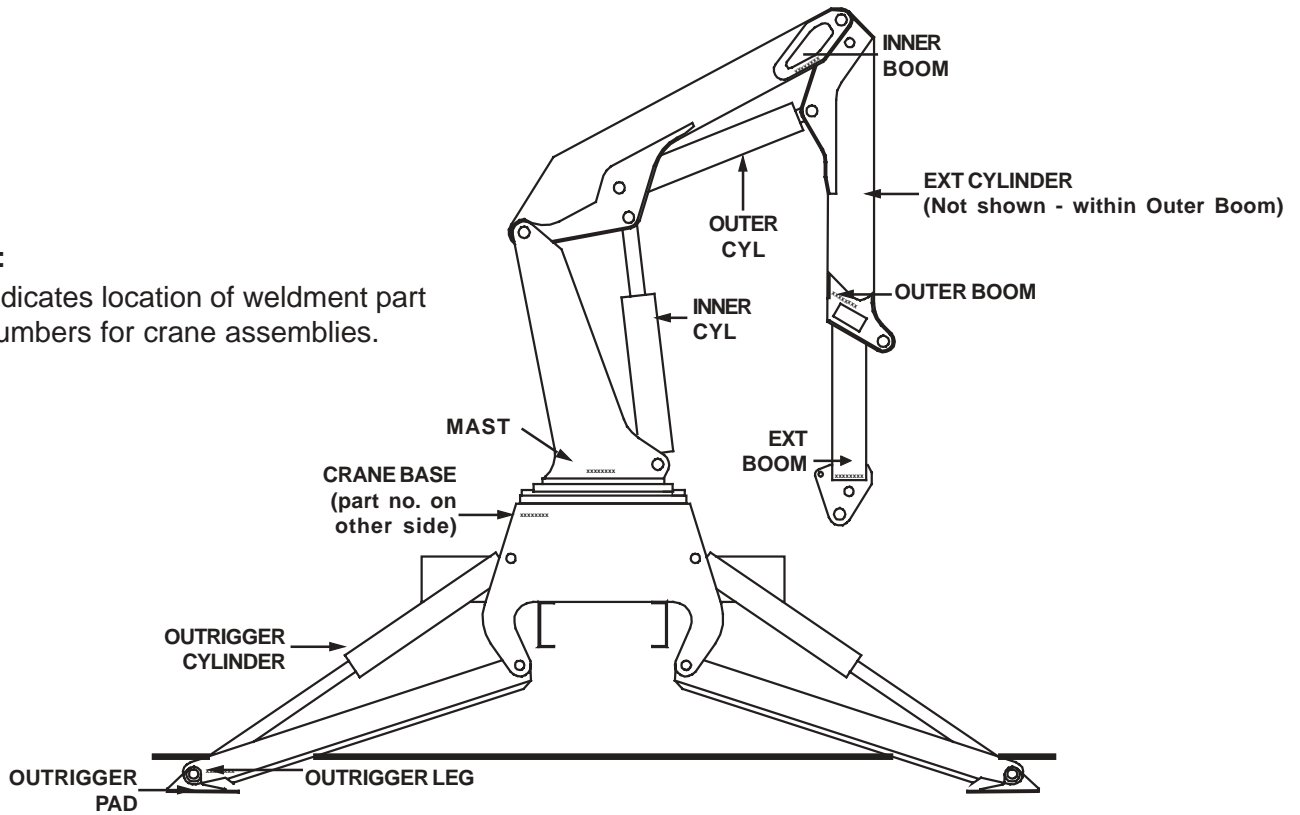

GREASE ZERK LOCATIONS & LUBRICANT REQUIREMENTS

Crane shown with 14K160TH tirehand attached.

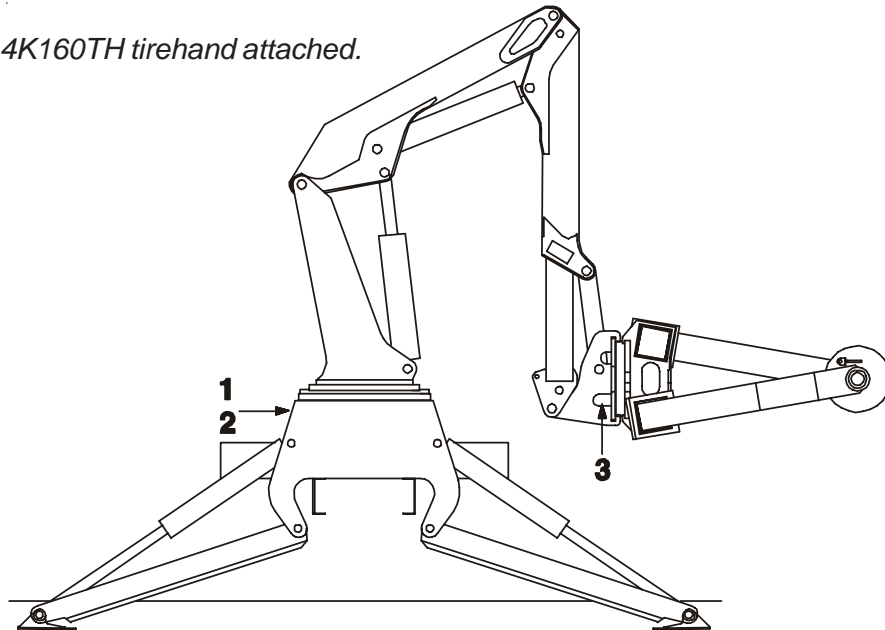

ITEM	LOCATION DESCRIPTION	LUBRICANT	FREQUENCY
1.	TURNTABLE/BEARING GREASE EXTENSION *ROTATE CRANE WHILE GREASING	SHELL ALVANIA 2EP OR	WEEKLY
2.	DRIVE GEAR GREASE EXTENSION	SHELL RETINAX "A"	
3.	TIREHAND TURNTABLE GREASE EXTENSION		

NOTE: All application points must be greased weekly under normal work loads and moderate weather conditions. Under severe operating conditions, lubrication should be performed more frequently. See Volume 1; Operation, Maintenance and Repair for additional lubrication requirements.

RECOMMENDED SPARE PARTS LIST

1 YEAR SUPPLY 23516 CRANE FOR MANUAL: 99903471

This spare parts list does not necessarily indicate that the items can be expected to fail in the course of a year. It is intended to provide the user with a stock of parts sufficient to keep the unit operating with the minimal down-time waiting for parts. There may be parts failures not covered by this list. Parts not listed are considered as not being Critical or Normal Wear items during the first year of operations and you need to contact the distributor or manufacturer for availability.

ASSEMBLY DESIGNATION	ITEM NO.	PART NO.	DESCRIPTION	QTY	CODE	SHELF LIFE (MO)	ORDER QTY
3D312990.01.20000201	OUTRIGGER CYLINDER						
	3	6H165035	HEAD	2	W		
	4	6I312990	PISTON	2	W		
	16	70034454	BEARING	8	W		
	23	73540072	CHECK VALVE	4	C		
41715809.01.20000421	24	9C312990	SEAL KIT	2	W		
	INNER BOOM ASM						
3D293990.01.20000201	7	70034454	BEARING	2	W		
	INNER CYLINDER						
41715810.01.20000421	3	6IX80243	PISTON	1	W		
	20	6HX80040	HEAD	1	W		
	21	70034454	BEARING	3	W		
	22	73540082	C'BAL VALVE	1	C		
	23	9C293990	SEAL KIT	1	W		
3D298990.01.20000201	OUTER BOOM ASM						
	4	60109341	WEAR PAD	4	W		
41715834.01.20000421	14	60120168	WEAR PAD	2	W		
	OUTER CYLINDER						
	3	6H075035	HEAD	1	W		
	4	6I298990	PISTON	1	W		
	23	73540082	C'BAL VALVE	1	C		
3D295990.01.20000201	24	9C298990	SEAL KIT	1	W		
	EXTENSION BOOM ASM						
99901234.01.20000421	3	60122274	WEAR PAD	2	W		
	EXTENSION CYLINDER						
	5	6H060030	HEAD	1	W		
	6	6I295990	PISTON	1	W		
	19	70034455	BEARING	4	W		
51715011.01.20000421	20	73540082	C'BAL VALVE	1	C		
	22	9B295990	SEAL KIT	1	W		
	HYD KIT-CRANE ROTN						
91715845.02.20000613	8	73051473	MOTOR-ROTN	1	W		
	HYDRAULIC KIT						
51715011.01.20000421	36	73054980	VALVE	2	C		
	RESERVOIR ASM						
REF	REF	77042083	BATTERY-REMOTE CONTROL	2	C		
		73052088	FILTER ELEMENT (PART OF PM KIT)	6	P		

INSTALLATION

GENERAL

This section contains specific instructions for the installation of your crane. Prior to installing the crane and hydraulic components, make sure the chassis is ready to receive the crane (refer to VOLUME 1, Installation).

CRANE MOUNTING

- See SPECIFICATIONS in Section 1 for crane weight. Using an overhead hoist and fabric slings of adequate capacity, lift the crane about a foot to see if the crane is adequately balanced. If not, lower hoist and adjust slings. Re-check balance and re-position crane until mounting surface is level.
- Install the truck frame support so that the tie-down studs pass through the supports (See figure below). Cut the support to the inside dimensions of the truck frame. Allow about 1/16" extra. Grind the end of the support to fit inside the frame channel. Use a hammer to drive it into position if necessary.
- Allow sufficient clearance between the cab and crane base, at least 4" (10.2cm). Position the crane on the chassis per the applicable installation drawing, centering the mounting slots over the truck frame rails. While holding crane with hoist, start mounting hardware per Figure below. Note position of support weldments on truck frame. Hand tighten nuts. Observe underside of crane base. No clearance between base and frame is allowed.
- Torque the 1 1/4"-7 UNC Grade 5 mounting hardware to 840 ft-lbs (116 kg-m). When torquing the mounting hardware the following precautions must be followed:
 - Never use lock washers.
 - Hardened washers must be used, and under the turning element, whether the turning element is the nut or the head of the bolt.
 - Torque values specified are with residual oils or without special lubricants applied to the threads. If special lubricants are used, such as Never-Seize compound graphite and oil, molybdenum disulphite colloidal copper or white lead, reduce torque values 10%. Torque values for threaded fasteners are not affected with the use of Loctite.
 - Do not use rusty fasteners, the rust will alter torque values significantly.

CAUTION

DO NOT ATTEMPT TO APPLY THE SAME TORQUE TO THE TIE ROD AND SELF-LOCKING NUTS AS SHOWN IN THE TORQUE DATA CHART. DO NOT EXCEED 840 FT. LBS. (116 KG-M). EXCEEDING THIS TORQUE VALUE COULD DAMAGE EITHER THE CHASSIS OR CRANE BASE.

POWER WRENCHING IS NOT RECOMMENDED UNTIL THE LEAD THREAD OF THE NUT INSERT IS ENGAGED BY HAND TURNING.

- Weld (4) 60122834 bars into place per the bottom view of the installation kit drawing (93715856) in parts manual.
- Touch up paint on crane and chassis as necessary.

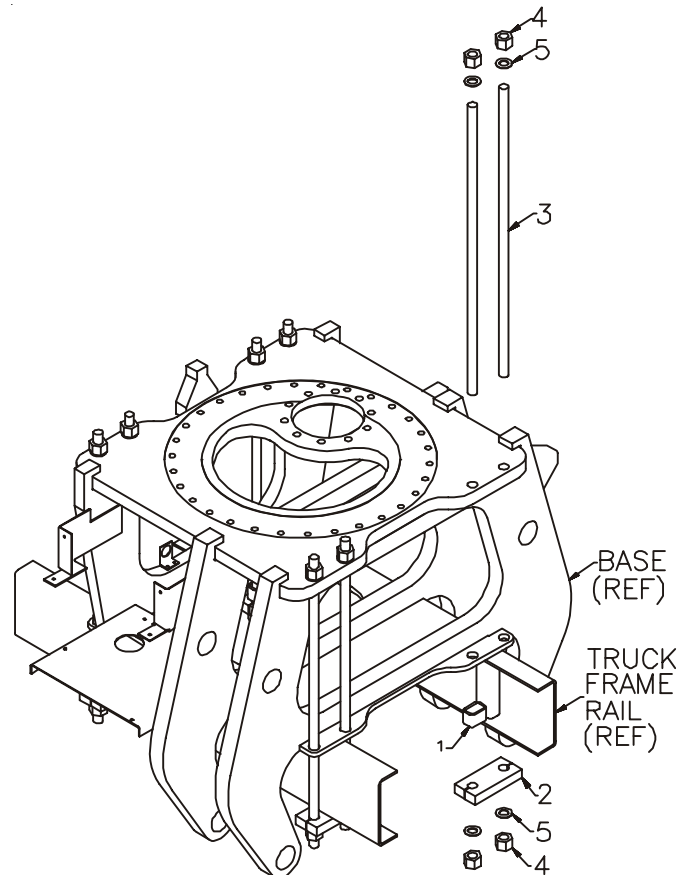

- SUPPORT**
- CLAMP PLATE**
- TIE DOWN STUD**
- NUT**
- WASHER-FLAT/HARD**

CRANE INSTALLATION

HYDRAULIC INSTALLATION

Refer to the hydraulic diagrams in the Parts Section for hose routings, brackets, filters, etc. Install all hoses and fittings, making certain all connections are properly tightened.

Fill the reservoir with hydraulic fluid. Open the valve at the suction line beneath the reservoir and any valves which may have been installed in the return line.

CAUTION

FAILURE TO OPEN THE GATE VALVE WILL RESULT IN A DRY RUNNING PUMP WHICH MAY DAMAGE THE PUMP.

7. Open the return gate valve.
8. Start the vehicle's engine and engage the PTO. Allow the system to run for about five minutes and then check the vacuum gauge on the suction-line filter (it should read 8" mercury or less). If the vacuum reading is too high, check to make certain that the gate valve is opened completely. If the valve is fully opened, check for a collapsed or restricted suction line.
9. Cycle all hydraulic functions. Check for leaks, and refill the reservoir if necessary.

SECTION 3. REPLACEMENT PARTS

PARTS INFORMATION	2
CRANE IDENTIFICATION	2
SERIAL NUMBER PLACARD	2
CYLINDER IDENTIFICATION	2
WELDMENT IDENTIFICATION	2
ORDERING REPAIR PARTS	2
CYLINDER PART NUMBER LOCATION	2
BASE & OUTRIGGER ASM (41715824)	3
OUTRIGGER CYLINDER (3D312990)	4
MAST ASM (41715808)	5
INNER BOOM ASM (41715809)	6
INNER CYLINDER (3D293990)	7
OUTER BOOM ASM (41715810)	8
OUTER CYLINDER (3D298990)	9
EXTENSION BOOM ASM (41715834)	10
EXTENSION CYLINDER (3D295990)	11
VALVEBANK ASM (51715851)	12
VALVEBANK-10 SECTION (73733415)	13
VALVEPACK-DUAL C' BAL (70731795)	13
HYD KIT-CRANE ROTN (99901234)	14
GEAR BOX (70056564)	15
HYDRAULIC KIT - RESERVOIR (99901235)	16
RESERVOIR ASM (51715011)	17
HYD KIT-INNER CYLINDER (99903149)	18
HYD KIT-OUTER CYLINDER (99903150)	19
HYD KIT-EXT CYLINDER (99903151)	20
HYD KIT-BULKHEAD LAYOUT (99903152)	21
HYD KIT-OUTRIGGERS (99903153)	22
HYD KIT-SCHEMATIC (99903210)	23
HYD KIT (91717986-1)	24
HYD KIT (91717986-2)	25
CONTROL KIT (90715855)	26
INSTALLATION KIT (93715856)	27
DECAL KIT-CRANE (95715871)	28
RADIO REMOTE KIT (73733417)	29
KIT-RADIO RMT-NOVA (73733481)	30
WIRING SCHEMATIC - CHASSIS & CRANE (99903201-1) (THRU 8/02)	31
WIRING SCHEMATIC - BODY (99903201-1) (THRU 8/02)	32
WIRING SCHEMATIC (99903201-2) (THRU 8/02)	33
ELECTRICAL SCHEMATIC - CHASSIS- DUMP SYSTEM (99903557-1) (EFF. 9/02)	34
ELECTRICAL SCHEMATIC - BODY- DUMP SYSTEM (99903557-1) (EFF. 9/02)	35
ELECTRICAL SCHEMATIC - COMMANDER IV W/DUMP SYS, SPD CTRL (99903557-2) (EFF. 9/02)	36
ELECTRICAL CONTROL BOX (41718269-1)	37
ELEC CONTROL BOX ASM (41718269-2)	38
ELEC CONTROL BOX (41718269-3)	39
CHASSIS WIRING (99903160)	40
HYDRAULIC SHUTDOWN KIT (99903465)	41
23516 SHUTDOWN CONVERSION KIT (99903466)	42
GEAR REDUCER (71570570)	43

PARTS INFORMATION

GENERAL

This section contains the exploded parts drawings and accompanying parts lists for the assemblies used on this crane. These drawings are intended to be used in conjunction with the instructions found in the REPAIR section in Volume 1.

WARNING

DO NOT ATTEMPT TO REPAIR ANY COMPONENT WITHOUT READING THE INFORMATION CONTAINED IN THE REPAIR SECTION IN VOLUME 1. PAY PARTICULAR ATTENTION TO STATEMENTS MARKED WARNING, CAUTION, OR NOTE IN THAT SECTION. FAILURE TO COMPLY WITH THESE INSTRUCTIONS MAY RESULT IN DAMAGE TO THE EQUIPMENT, PERSONAL INJURY, OR DEATH.

CRANE IDENTIFICATION

Every IMT crane has an identification placard (see figure) attached to the inner boom, mast, or crane base. When ordering parts, communicating warranty information, or referring to the unit in correspondence, always include the serial number and model numbers. All inquiries should be addressed to:

Iowa Mold Tooling Co., Inc.
Box 189, Garner, IA 50438-0189
Telephone: 641-923-3711
Technical Support Fax: 641-923-2424

IOWA MOLD TOOLING CO., INC. BOX 189, GARNER, IA 50438-0189	
MODEL NUMBER	<input type="text"/>
SERIAL NUMBER	<input type="text"/>
MFG DATE	<input type="text"/>
70029119	

SERIAL NUMBER PLACARD

CYLINDER IDENTIFICATION

To insure proper replacement parts are received, it is necessary to specify the complete number/letter sequence for any part requested. Part numbers may be cross checked by comparing the stamped identification on the cylinder case (See figure below) against the information contained in the service manual. You must include the part number stamped on the cylinder case when ordering parts.

WELDMENT IDENTIFICATION

Each of the major weldments - base, mast, inner boom, outer boom, extension boom and outrigger weldments bear a stamped part number. Any time a major weldment is replaced, you must specify the complete part number as stamped on the weldment.

ORDERING REPAIR PARTS

When ordering replacement parts:

1. Give the model number of the unit.
2. Give the serial number of the unit.
3. Specify the complete part number. When ordering cylinder parts, or one of the main weldments, always give the stamped part number.
4. Give a complete description of the part.
5. Specify the quantity required.

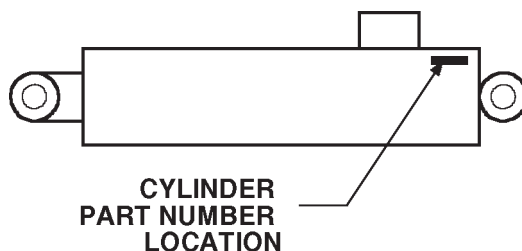

CYLINDER PART NUMBER LOCATION

BASE & OUTRIGGER ASM (41715824)

1.52715802	BASE	1
2.52719324	PIN (WAS 52715827)	4
3.60109337	PIN RETAINER PLATE 3" (WAS 60106332)	4
4.72060148	CAP SCR 5/8-11x1-1/4 HHGR5	4
5.52715828	LEG	2
6.52715826	PAD	2
7.52715829	PIN	2
8.72063056	WASHER 3/4 LOCK	2
9.72060181	CAP SCR 3/4-10X1 HHGR5	2
10.71056562	TURNTABLE GEAR	1
11.72063115	WASHER 7/8 FLAT HARD	30
12.72601622	CAP SCR 7/8-9X5 HHGR8	30
13.3D312990	CYLINDER	2
14.70056564	GEAR BOX W/BRAKE	1
15.72601651	CAP SCR 3/4-10X2 SH	10
16.72063055	WASHER 5/8 LOCK	4
17.72661607	RETAINING RING	4
18.99903611	INST, HYD SHUTDOWN PROCESS REF	
19.53000716	GREASE EXT.	REF

WARNING

ANYTIME A GEAR-BEARING BOLT IS REMOVED, IT MUST BE REPLACED WITH A NEW BOLT OF THE IDENTICAL GRADE AND SIZE. FAILURE TO REPLACE GEAR-BEARING BOLTS MAY RESULT IN BOLT FAILURE DUE TO METAL FATIGUE, CAUSING SERIOUS INJURY OR DEATH.

NOTE

ANYTIME THE PIN RETAINER PLATE BOLTS HAVE BEEN REMOVED, APPLY LOCTITE 262 TO THE THREADS BEFORE REASSEMBLY.

TURNTABLE BEARING BACKLASH= .008"-.013" (.203-.330mm).

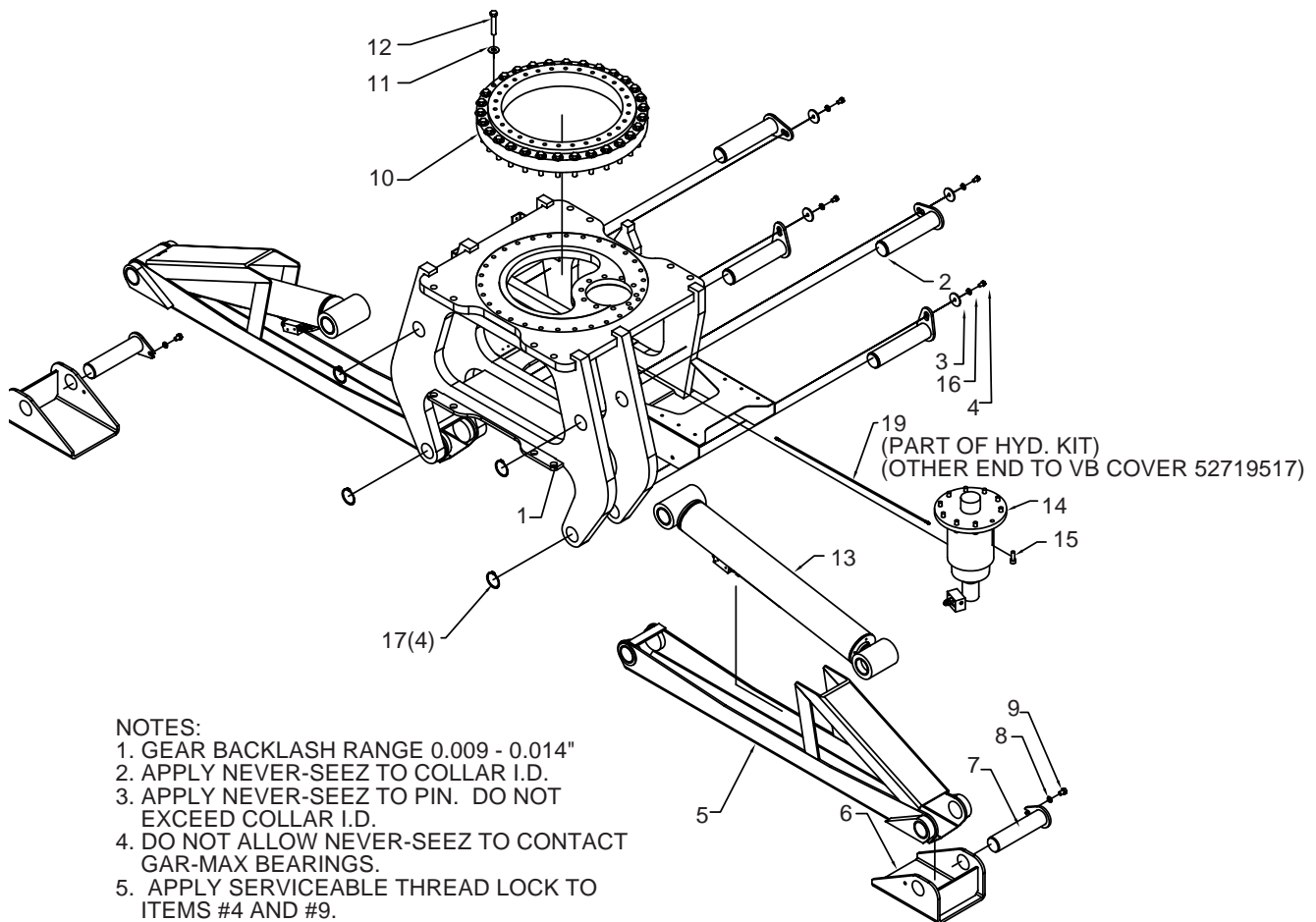

OUTRIGGER CYLINDER (3D312990)

1.4D312990	CASE ASM INCL:16)	1
2.4G312990	ROD ASM (INCL:16)	1
3.6H165035	HEAD	1
4.6I312990	PISTON	1
5.6C300035	STOP TUBE	1
6.6A025035	WAFER LOCK (PART OF 24)	1REF
7.7Q072257	O-RING (PART OF 24)	1REF
8.7T66P650	PISTON SEAL (PART OF 24)	1REF
9.7T61N218	LOCK RING (PART OF 24)	1REF
10.7T2N4065	WEAR RING (PART OF 24)	2REF
11.7R546035	U-CUP LOADED (PART OF 24)	1REF
12.7Q10P361	BACKUP RING (PART OF 24)	1REF
13.7Q072361	O-RING (PART OF 24)	1REF
14.7R14P035	ROD WIPER (PART OF 24)	1REF
15.7T2N2X37	WEAR RING (PART OF 24)	2REF
16.70034454	BEARING (PART OF 1&2)	4REF
17.72533166	ADAPTER #8MFACE #8MSTR	4
18.70146078	TUBE ASM	1
19.70146079	TUBE ASM	1
21.5V312990	VALVE BLOCK (INCL:23)	1
22.72062103	NUT 3/8-16 LOCK	1
23.73540072	VALVE-CHK 16GPM(PART OF 21)	2REF
24.9C312990	SEAL KIT (INCL:6-15)	1

NOTE

IT IS RECOMMENDED THAT ALL COMPONENTS OF THE SEAL KIT BE REPLACED WHENEVER THE CYLINDER IS DISASSEMBLED. THIS WILL REDUCE FUTURE DOWNTIME.

APPLY "LUBRIPLATE #630-2" MEDIUM HEAVY, MULTI-PURPOSE LUBRICANT OR EQUIVALENT TO ALL PISTON AND HEAD GLANDS, LOCK RING AND ROD THREADS BEFORE ASSEMBLY.

USE "NEVER-SEEZ" OR EQUIVALENT BETWEEN THE HEAD AND THE CASE WHEN ASSEMBLING THE CYLINDER.

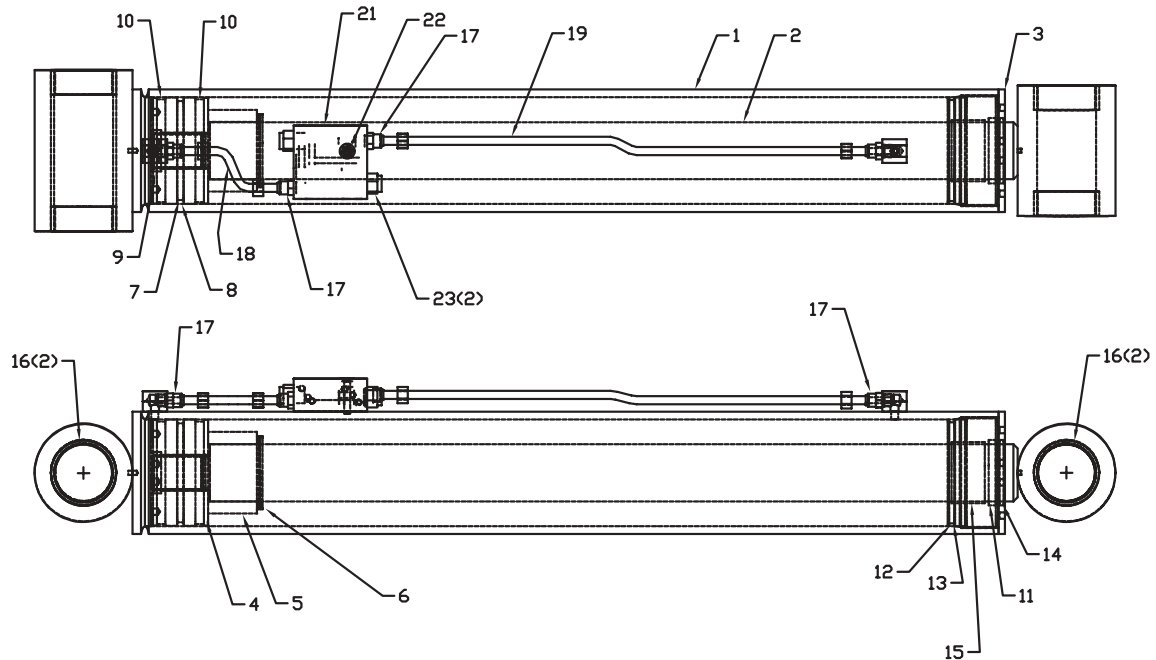

MAST ASM (41715808)

1. 52715778	MAST	1
2. 72601622	CAP SCR 7/8-9X5 HHGR8	26
3. 72063115	WASHER 7/8 FLAT HASTM F436 (WAS 72063009)	26
4. 70029119	SERIAL NUMBER PLACARD	1
5. 72066340	POP RIVET 1/8X3/8GRIP	2
6. 70029595	THREADED PLUG 1-8	1

WARNING

ANYTIME A GEAR-BEARING BOLT IS REMOVED, IT MUST BE REPLACED WITH A NEW BOLT OF THE IDENTICAL GRADE AND SIZE. FAILURE TO REPLACE GEAR-BEARING BOLTS MAY RESULT IN BOLT FAILURE DUE TO METAL FATIGUE, CAUSING SERIOUS INJURY OR DEATH.

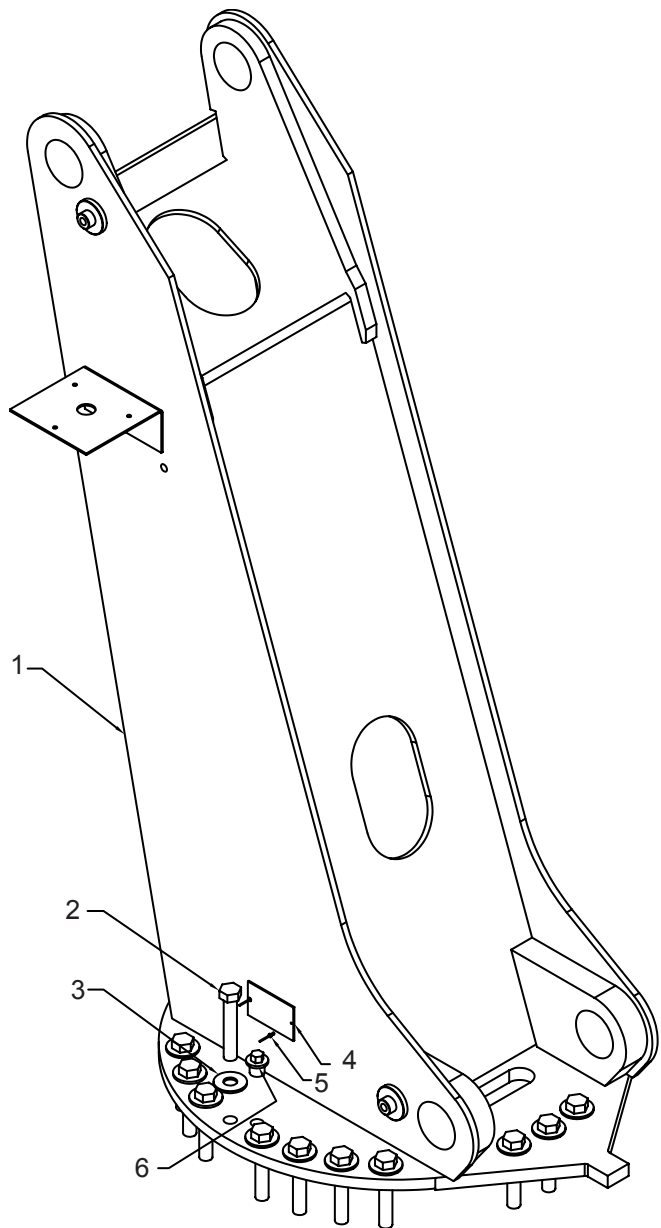

INNER BOOM ASM (41715809)

1.52715773	INNER BOOM (INCL:7)	1
2.52719321	PIN (WAS 52715804)	2
3.52719322	PIN (WAS 52715805)	3
4.3D293990	CYLINDER	1
5.72060148	CAP SCR 5/8-11X1-1/4 HHGR5 (WAS 72060149)	5
6.72063055	WASHER 5/8 LOCK	5
7.71024357	BEARING (PART OF 1) (WAS 70034454; 71024355)	2REF
8.60107648	HOSE CLAMP	1
9.72062103	NUT 3/8-16 LOCK	1
10.60109337	RETAINER PLATE	5
11.72661607	RETAINING RING	5

NOTE
 ANYTIME THE PIN RETAINER PLATE BOLTS HAVE BEEN REMOVED, APPLY LOCTITE 262 TO THE THREADS BEFORE REASSEMBLY.

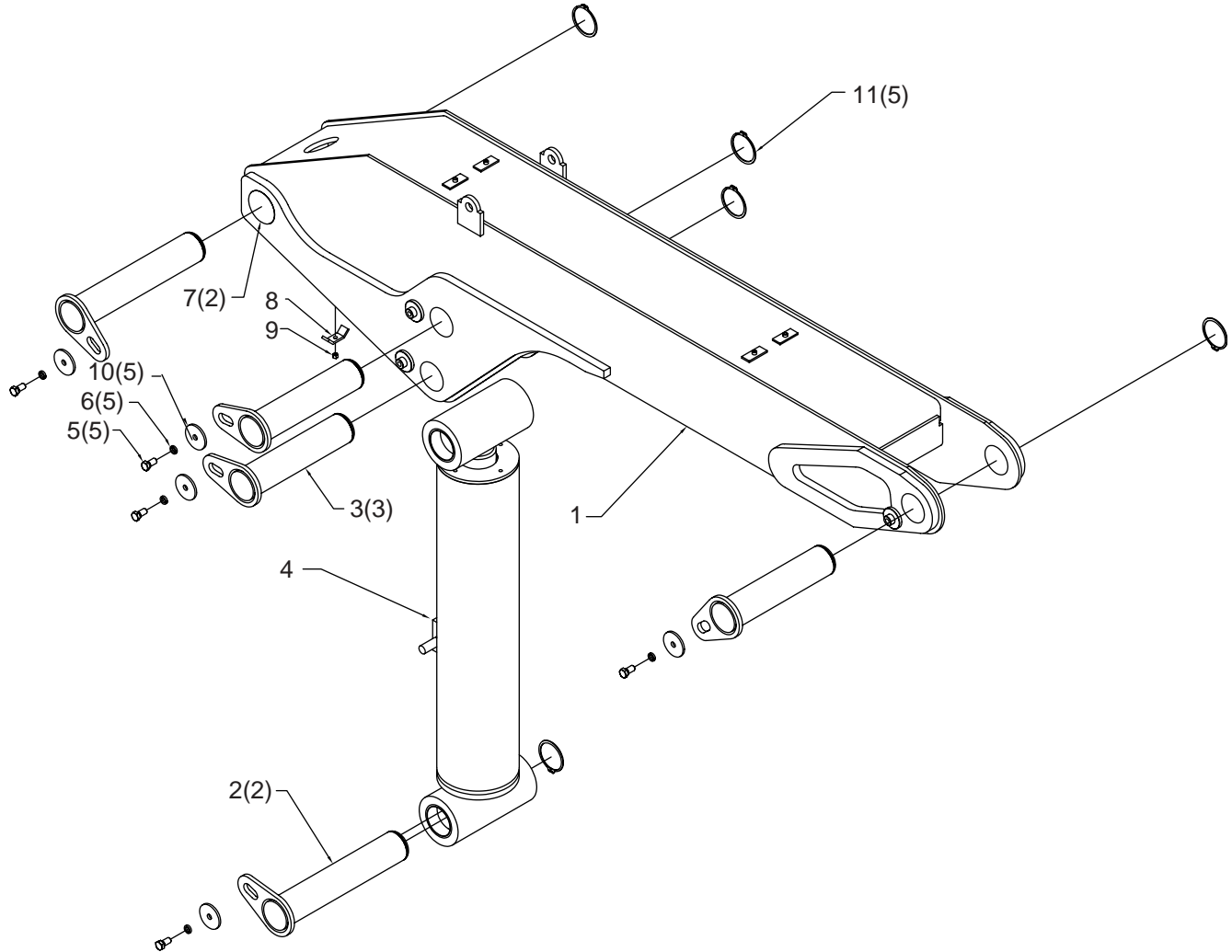

- NOTES:**
1. APPLY NEVER-SEEZ TO COLLAR I.D.
 2. APPLY NEVER-SEEZ TO PINS. DO NOT EXCEED THE WIDTH OF COLLARS.
 3. DO NOT ALLOW NEVER-SEEZ TO COME IN CONTACT WITH GAR-MAX BEARINGS.
 4. USE SHIMS 60122815 AND 60122816 AS REQUIRED.

INNER CYLINDER (3D293990)

1.4D293990	CASE ASM (INCL:21)	1REF
2.4G293990	ROD ASM (INCL:21)	1REF
3.6IX80243	PISTON	1REF
4.6A025040	WAFER LOCK (PART OF 23)	1REF
5.7T66P080	PISTON SEAL (PART OF 23)	1REF
6.7Q072263	O-RING (PART OF 23)	1REF
7.7Q072443	O-RING (PART OF 23)	1REF
8.7Q10P443	BACKUP RING (PART OF 23)	1REF
9.7T61N243	LOCK RING (PART OF 23)	1REF
10.7T2N4080	WEAR RING (PART OF 23)	2REF
11.7R14P040	ROD WIPER (PART OF 23)	1REF
12.7R546040	U-CUP LOADED (PART OF 23)	1REF
13.7T2N2X42	WEAR RING (PART OF 23)	1REF
14.72062103	NUT 3/8-16 LOCK	1
15.72532141	PLUG #8MSTR	2
16.72533166	ADAPTER #8MFACE#8MSTR	4
17.70146073	TUBEASM	1
18.70146074	TUBEASM	1
19.5V298990	VALVE BLOCK (INCL:22)	1
20.6HX80040	HEAD	1REF
21.70034454	BEARING (PART OF 1&2)	4REF
22.73540082	C'BAL VALVE 16GPM (PART OF 19)	1REF
23.9C293990	SEAL KIT (INCL:4-13)	1REF
24.77041561	PRESSURE SWITCH	1

NOTE

IT IS RECOMMENDED THAT ALL COMPONENTS OF THE SEAL KIT BE REPLACED WHENEVER THE CYLINDER IS DISASSEMBLED. THIS WILL REDUCE FUTURE DOWNTIME.

APPLY "LUBRIPLATE #630-2" MEDIUM HEAVY, MULTI-PURPOSE LUBRICANT OR EQUIVALENT TO ALL PISTON AND HEAD GLANDS, LOCK RING AND ROD THREADS BEFORE ASSEMBLY.

USE "NEVER-SEEZ" OR EQUIVALENT BETWEEN THE HEAD AND THE CASE WHEN ASSEMBLING THE CYLINDER.

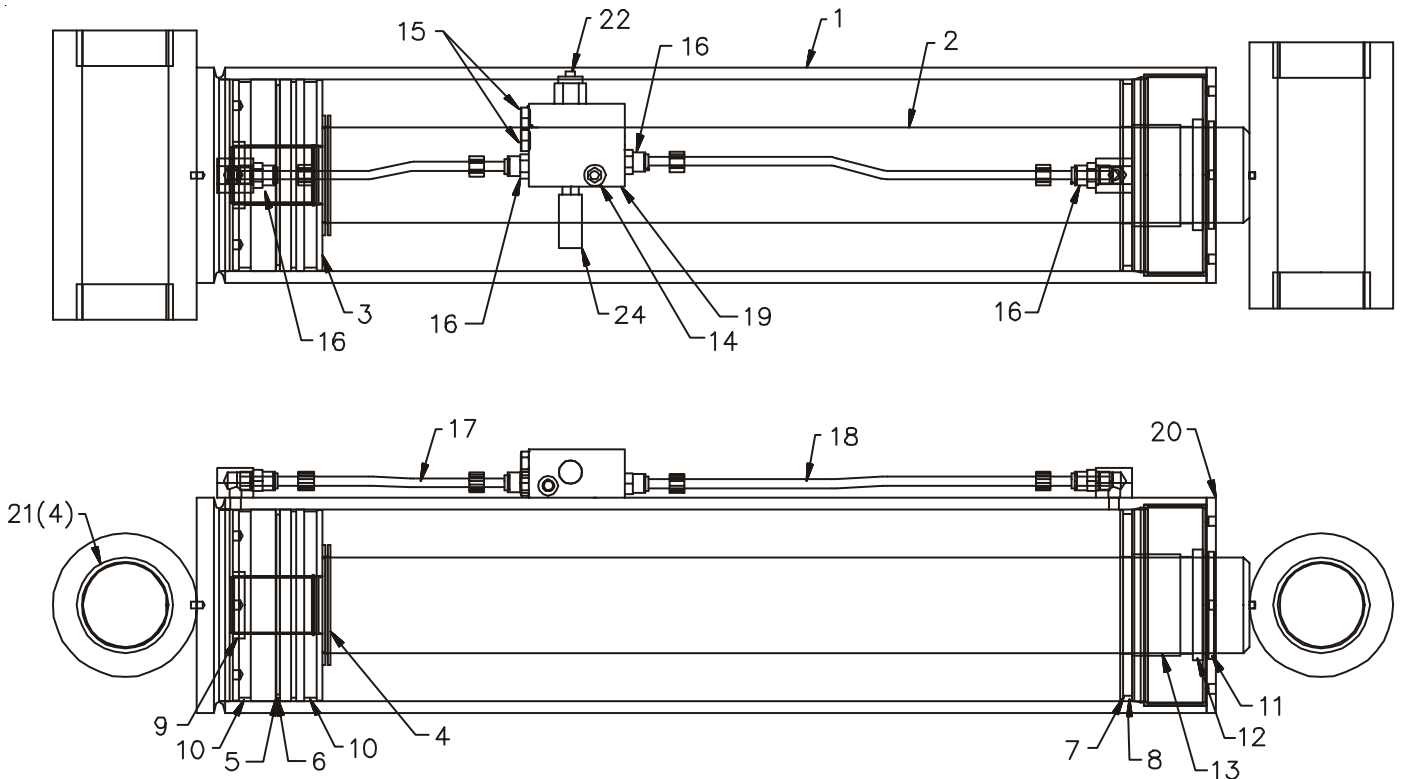

OUTER BOOM ASM (41715810)

1.52715775	OUTER BOOM	1
2.52719232	PIN (WAS 52715806)	2
3.60107438	PAD RETAINER PLATE	6
4.60109341	WEAR PAD	4
5.60122239	PIN	1
6.72063040	MACH BUSHING 2-1/2X10GA NR	2
7.72066138	RETAINING RING 2-1/2 EXT HD	2
8.60103305	HOSE CLAMP	1
9.72060148	CAP SCR 5/8-11X1-1/4 HHGR5 (WAS 72060149)	2
10.72063055	WASHER 5/8 LOCK	2
11.72062103	NUT 3/8-16 LOCK	1
12.3D298990	CYLINDER	1
13.60030032	WEAR PAD 1.44X2X4	2
14.60122821	WEAR PAD .4X8.25X8.25	2
15.72060091	CAP SCR 1/2-13X1 HHGR5	24
16.72063053	WASHER 1/2 LOCK	24
17.71024357	BUSHING BRZ 3.5ID X 4OD X 1.5LG 2REF (WAS 71024355)	2
18.60102954	SLEEVE	2
19.60109337	RETAINER PLT	2
20.72661607	RETAINING RING	2

NOTE
 ANYTIME THE PIN RETAINER PLATE BOLTS HAVE BEEN REMOVED, APPLY LOCTITE 262 TO THE THREADS BEFORE RE-ASSEMBLY.

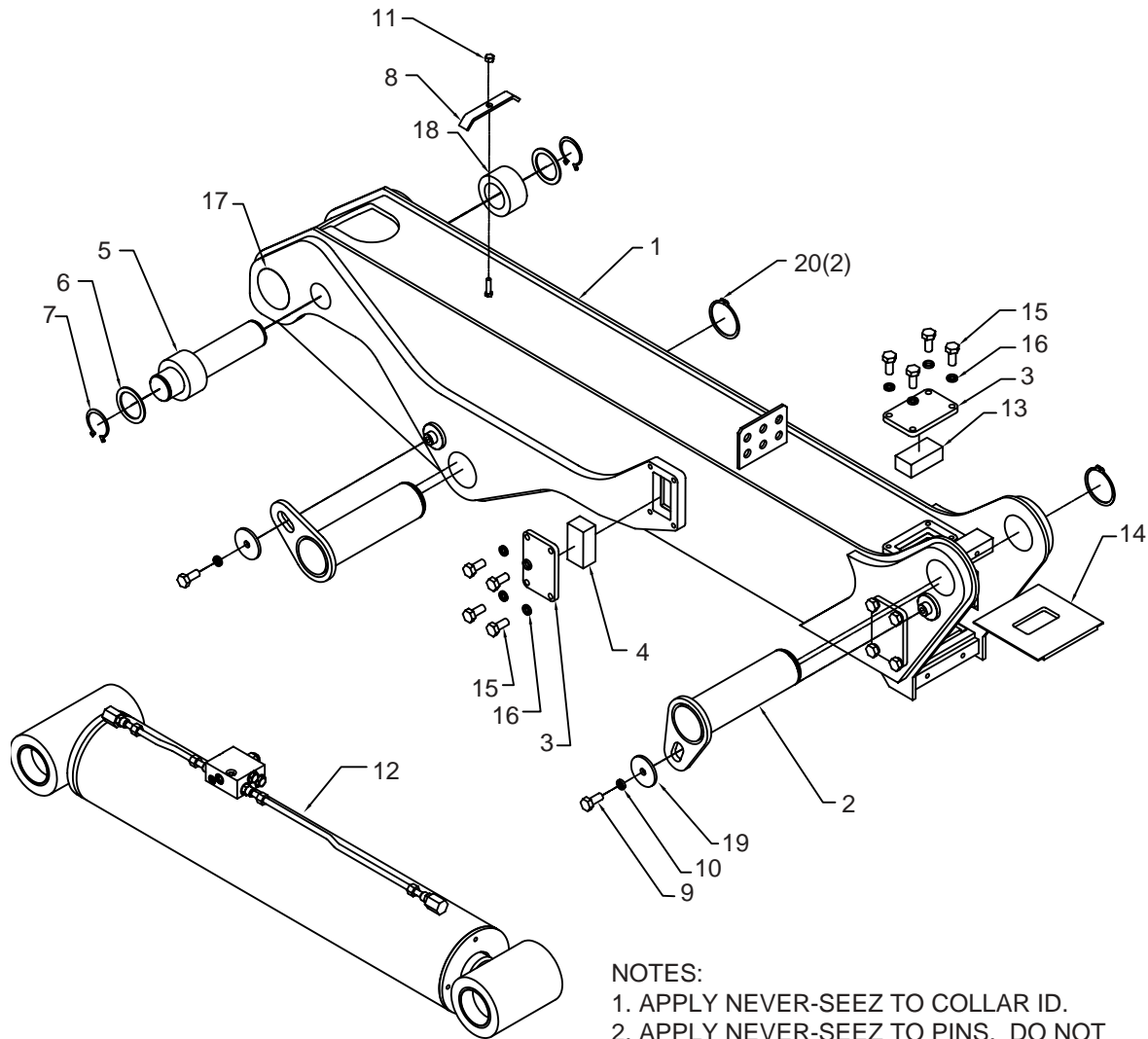

- NOTES:
1. APPLY NEVER-SEEZ TO COLLAR ID.
 2. APPLY NEVER-SEEZ TO PINS. DO NOT EXCEED WIDTH OF COLLARS.
 3. DO NOT ALLOW NEVER-SEEZ TO CONTACT GAR-MAX BEARINGS.
 4. USE SERVICEABLE THREAD LOCK ON ITEMS #9 AND #15 CAP SCREWS.

OUTER CYLINDER (3D298990)

1.4D298990	CASE ASM (INCL:16)	1
2.4G298990	ROD ASM (INCL:16)	1
3.6H075035	HEAD	1
4.6I298990	PISTON	1
5.6C100035	STOP TUBE	1
6.7Q072441	O-RING (PART OF 24)	1REF
7.7Q10P441	BACKUP RING (PART OF 24)	1REF
8.7R546035	U-CUP LOADED (PART OF 24)	1REF
9.7R14P035	ROD WIPER (PART OF 24)	1REF
10.7T2N2X37	WEAR RING (PART OF 24)	1REF
11.7Q072261	O-RING (PART OF 24)	1REF
12.7T66P075	PISTON SEAL (PART OF 24)	1REF
13.7T61N218	LOCK RING (PART OF 24)	1REF
14.6A025035	WAFER LOCK (PART OF 24)	1REF
15.7T2N4075	WEAR RING (PART OF 24)	2REF
16.70034454	BEARING (PART OF 1&2)	4REF
17.72533166	ADAPTER #8MFACE #8MSTR	4
18.70146073	TUBE ASM	1
19.70146075	TUBE ASM	1
20.72532141	PLUG #8MSTR	2
21.5V298990	VALVE BLOCK 16GPM (INCL 23)	1
22.72062103	NUT 3/8-16 LOCK	1
23.73540082	C'BAL VALVE (PART OF 21)	1REF
24.9C298990	SEAL KIT (INCL:6-15)	1

NOTE

IT IS RECOMMENDED THAT ALL COMPONENTS OF THE SEAL KIT BE REPLACED WHENEVER THE CYLINDER IS DISASSEMBLED. THIS WILL REDUCE FUTURE DOWNTIME.

APPLY "LUBRIPLATE #630-2" MEDIUM HEAVY, MULTI-PURPOSE LUBRICANT OR EQUIVALENT TO ALL PISTON AND HEAD GLANDS, LOCK RING AND ROD THREADS BEFORE ASSEMBLY.

USE "NEVER-SEEZ" OR EQUIVALENT BETWEEN THE HEAD AND THE CASE WHEN ASSEMBLING THE CYLINDER.

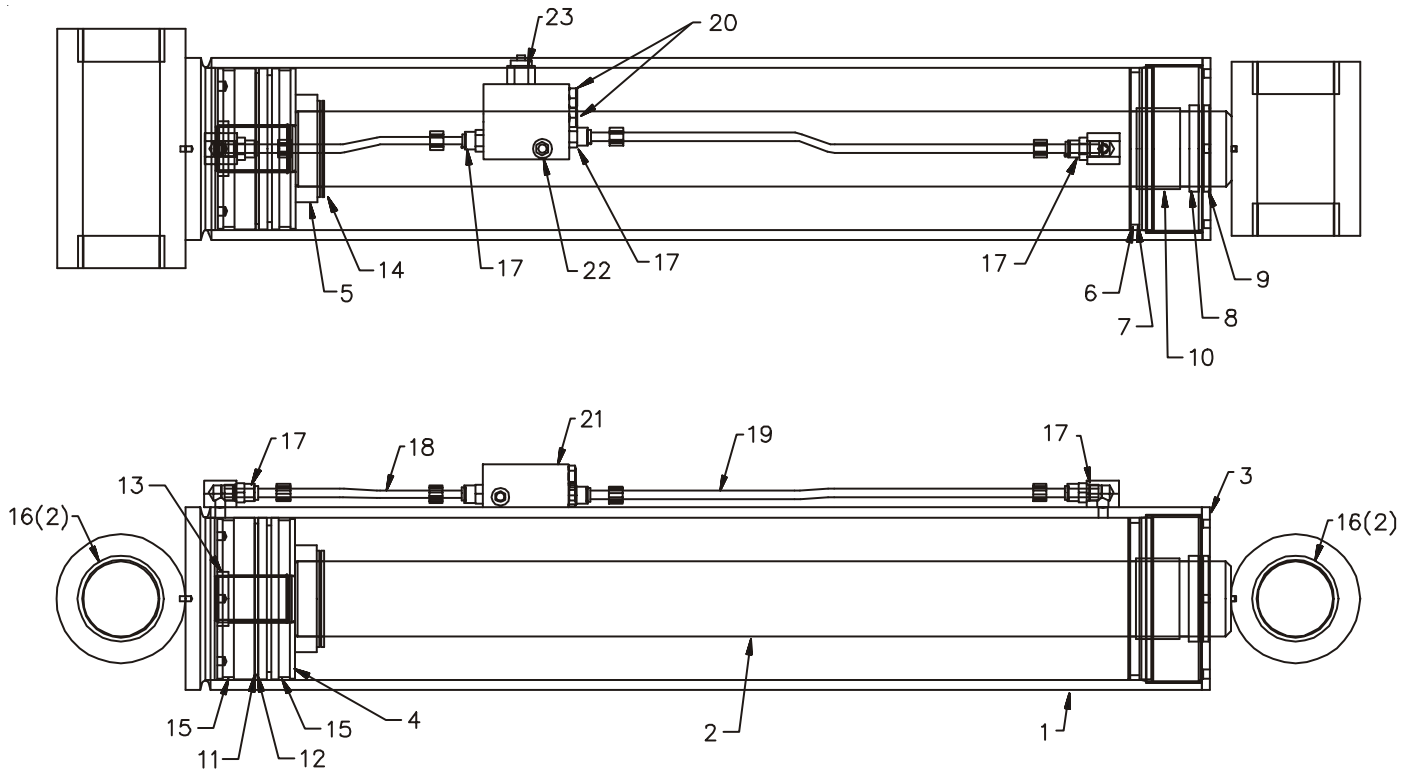

EXTENSION BOOM ASM (41715834)

1. 52715772	EXTENSION BOOM	1
2. 3D295990	CYLINDER	1
3. 60122274	WEAR PAD	2
4. 60122275	PIN	1
5. 72063040	MACH BUSHING 2-1/2X10GA NR	2
6. 72066138	RETAINING RING 2-1/2 EXT HD	2
7. 71024357	BEARING	2REF
	(WAS 70034454; 71024355)	
8. 60124267	SWIVEL LINK, 15 T	1
9. 52719325	PIN (52715812)	1
10. 72060148	CAP SCR 5/8-11 X 1.25 HH GR5Z	1
	(WAS 72060149)	
11. 72063055	WASHER 5/8 LOCK	1
12. 60109337	RETAINER PLT	1
13. 72661607	RETAINING RING	

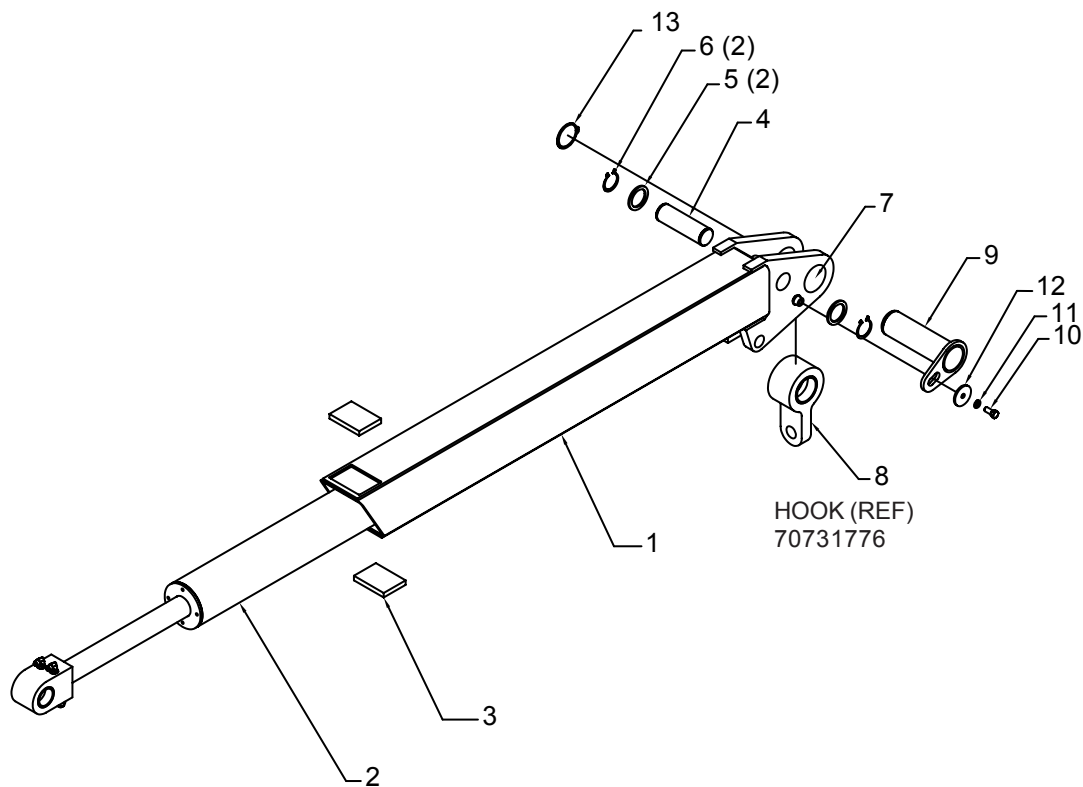

EXTENSION CYLINDER (3D295990)

1. 4D295990	CASE ASM	1
2. 52718610	ROD ASM (WAS 4H295990)	1
3. 6C295990	STOP TUBE 1-1/2	1
4. 3C300030	STOP TUBE 3"	2
5. 6H060030	HEAD	1
6. 6I295990	PISTON	1
7. 6A025030	WAFER LOCK (PART OF 21)	1REF
8. 7Q072253	O-RING (PART OF 21)	1REF
9. 7Q072358	O-RING (PART OF 21)	1REF
10. 7Q10P358	BACKUP RING (PART OF 21)	1REF
11. 7T2N8032	WEAR RING 1" (PART OF 21)	1REF
12. 7T2N4032	WEAR RING 1/2" (PART OF 21)	1REF
13. 7R546030	U-CUP LOADED (PART OF 21)	1REF
14. 7R14P030	ROD WIPER (PART OF 21)	1REF
15. 7T66P060	PISTON SEAL (PART OF 21)	1REF
16. 7T2N4060	WEAR RING (PART OF 21)	1REF
17. 7T295990	LOCK RING (PART OF 21)	1REF
19. 70034455	BEARING (PART OF 1&2)	4REF
20. 73540148	C'BAL VALVE (PART OF 2) (WAS 73540082)	2REF
21. 9B295990	SEAL KIT (INCL:7-17)	1

NOTE

IT IS RECOMMENDED THAT ALL COMPONENTS OF THE SEAL KIT BE REPLACED WHENEVER THE CYLINDER IS DISASSEMBLED. THIS WILL REDUCE FUTURE DOWNTIME.

APPLY "LUBRIPLATE #630-2" MEDIUM HEAVY, MULTI-PURPOSE LUBRICANT OR EQUIVALENT TO ALL PISTON AND HEAD GLANDS, LOCK RING AND ROD THREADS BEFORE ASSEMBLY.

USE "NEVER-SEEZ" OR EQUIVALENT BETWEEN THE HEAD AND THE CASE WHEN ASSEMBLING THE CYLINDER. KEEP AWAY FROM ALL SEALS.

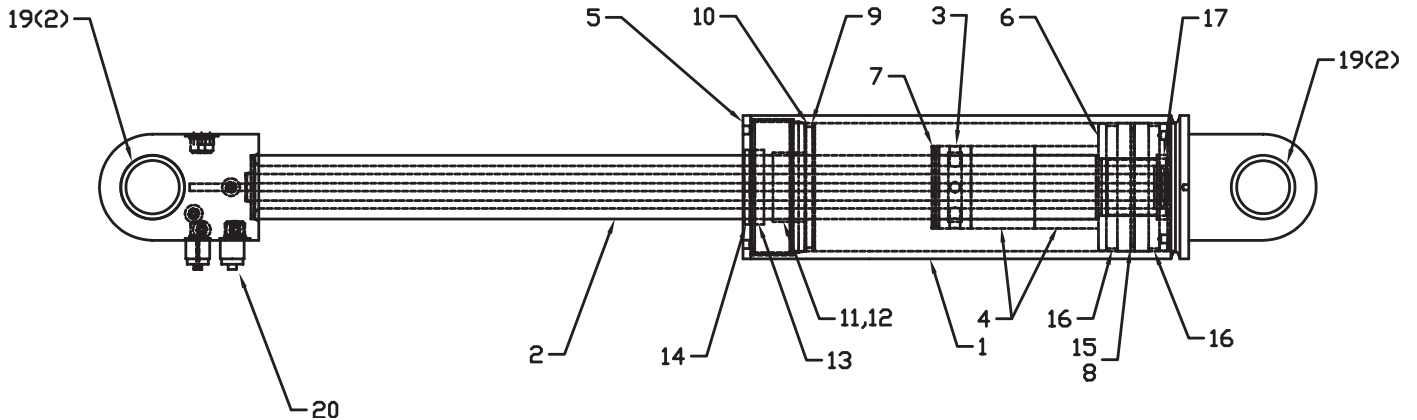
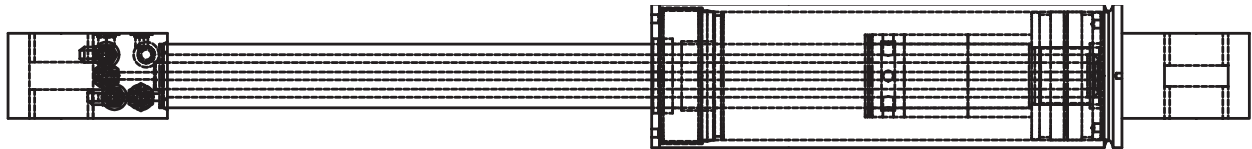

VALVEBANK ASM (51715851)

1.	73733415	VALVEBANK 10-SECT	1
2.	72053778	ELBOW #10MSTR #8MJIC 45°	18
3.	60107995	ELBOW-PR GUGE MOD RH	1
4.	72533651	ADPTR #12MSTR #16MJIC 45°	1
5.	72532987	NIPPLE-DISC 1/4 DIAGN W/CAP	1
6.	72532360	ADPTR #12MSTR #8MJIC	1
7.	72532670	ELBOW #8MJIC #8FJIC 45°	1

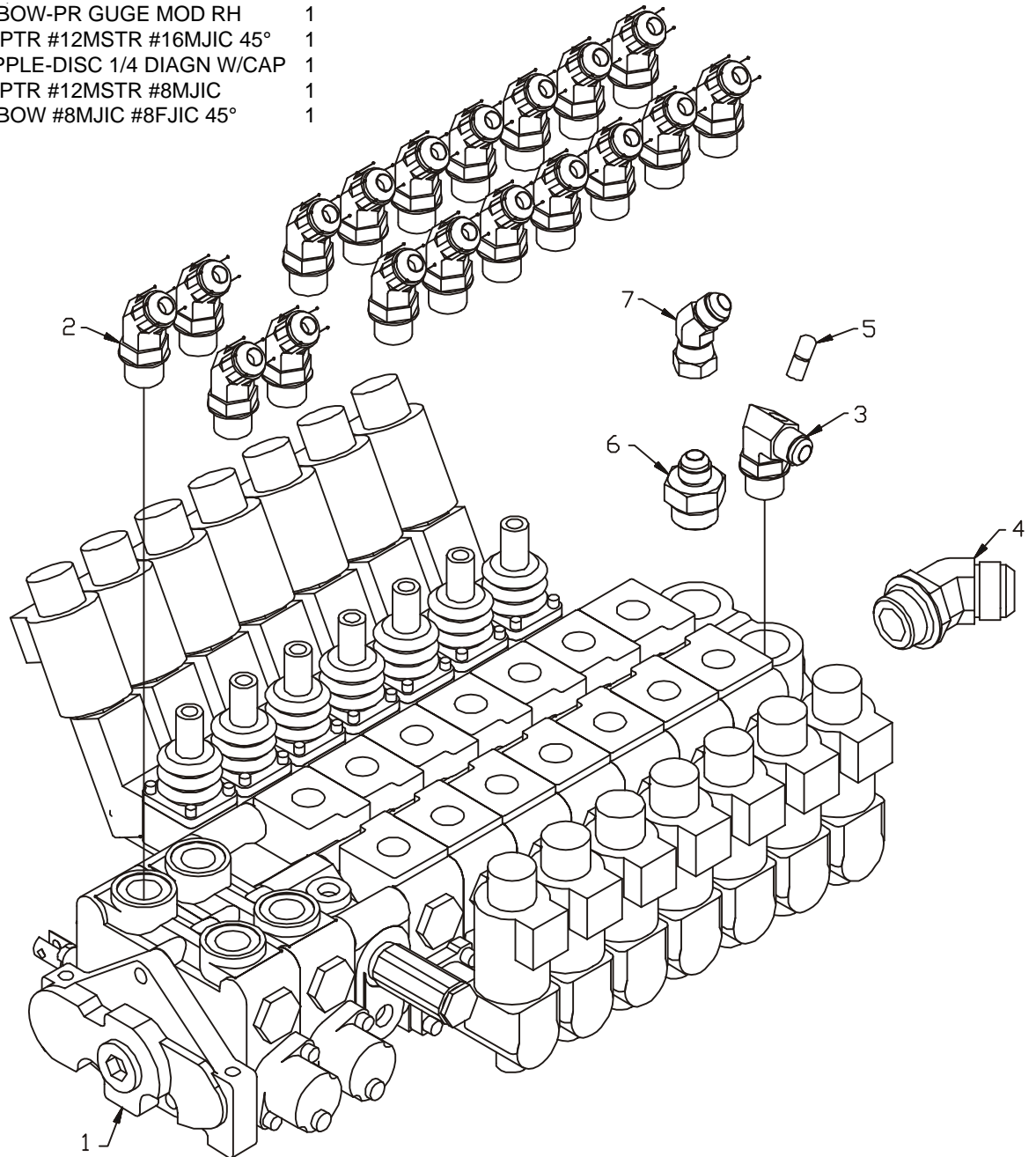

VALVEBANK-10 SECTION (73733415)

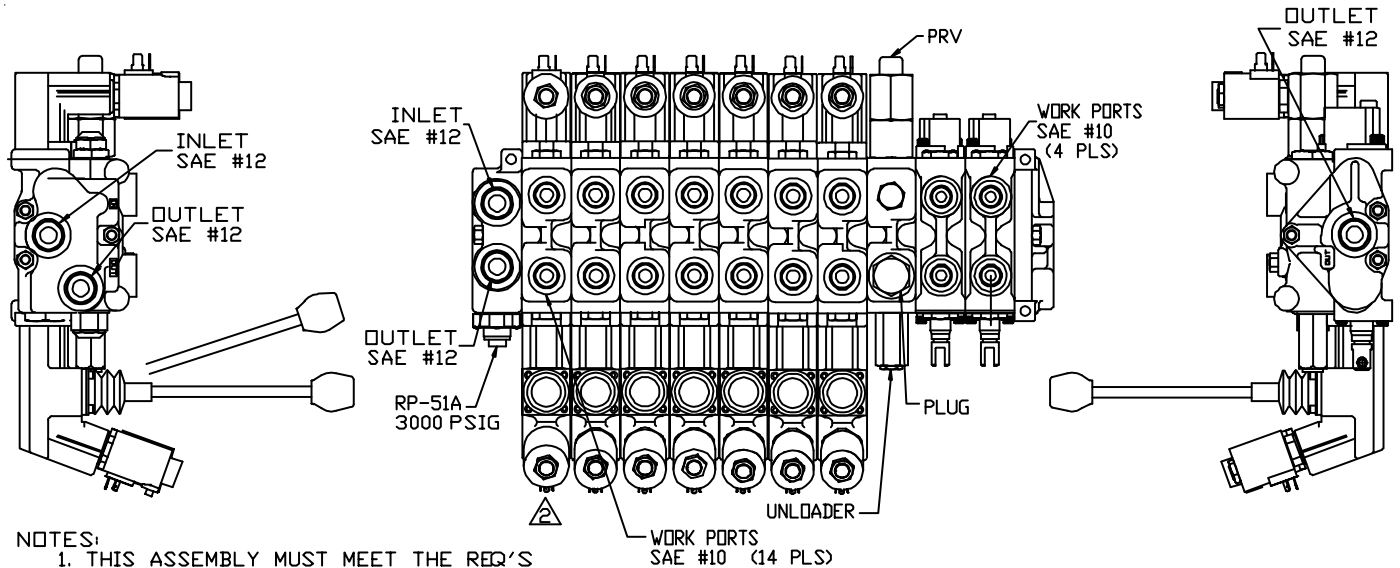

- NOTES:
 1. THIS ASSEMBLY MUST MEET THE REQ'S OF ENGRG SPEC 3.006.001
 ▲ PROPORTIONAL WORK SECTIONS HAVE 12 VDC COIL WITH 15.0 ohms RESISTANCE

70731795.01.20000613

VALVEPACK-DUAL C'BAL (70731795)

- | | | |
|------------|---------------|---|
| 1.70143099 | BODY | 1 |
| 2.73054538 | C'BAL VALVE | 2 |
| 3.70146108 | SHUTTLE VALVE | 1 |
| 6.7Q072017 | O-RING | 2 |

INSTALLATION TORQUE FOR ITEM 2 TO BE 45-50 FT.LBS.

INSTALLATION TORQUE FOR ITEM 3 TO BE 25-30 FT.LBS.

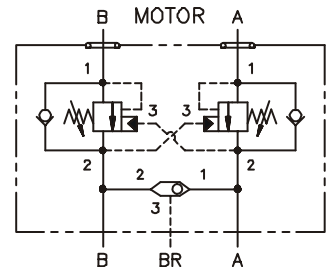
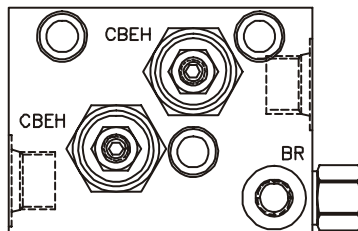

SYMBOL

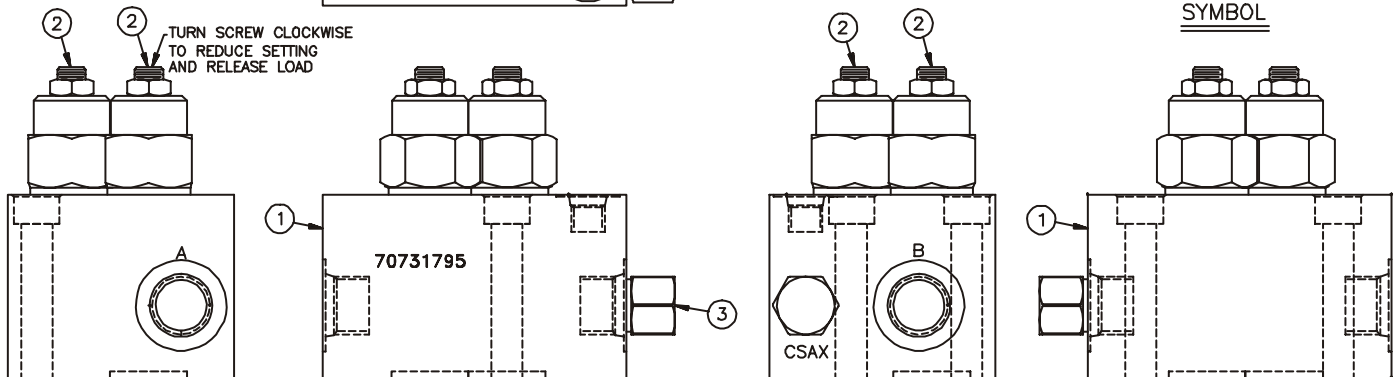

PORT IDENTIFICATION

- BR: -4 SAE ORB
- A, B: -8 SAE ORB

MOUNTING HOLES

- .41 DIA. HOLE THRU-
- .59 DIA. x .38 DEEP C'BORE-
- 3 PLACES.

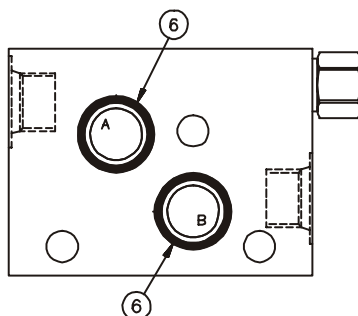

HYD KIT-CRANE ROTN (99901234)

1.70056564	GEAR BOX	1REF
2.60106032	STUD 1/2-13X2	2
3.72062080	NUT 1/2-13 LOCK	2
4.73054538	C'BAL VALVE	2REF
5.70731795	VALVEPACK-DUAL C'BAL	1
6.7Q072017	O-RING	2REF
7.72060757	CAP SCR 3/8-16X2-1/2 SH	3
8.73051473	MOTOR-ROTN	1
9.72053763	ELBOW #8MSTR #8MJIC 90°	2REF
10.51395429	HOSE-FF .50X45 #8#8	2REF
11.70146107	TUBEASM-ROTN	1
12.72532775	ADAPTER #4MSTR #6MJIC	2
13.53000718	GREASE EXT 55 OAL 53 HOSE	1REF

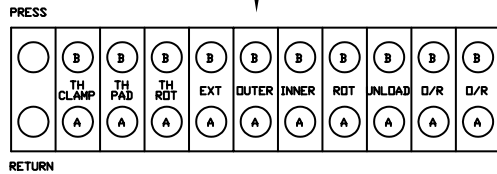

VALVE BANK ORIENTATION

NOTE:

1. FILL WITH 7 PINTS OF 90 EP GEAR OIL.
2. USE A CLEANER/PRIMER ON THREADS APPLY A SERVICABLE THREAD LOCKER TORQUE CAP SCREWS TO 75 FT-LBS.
3. BRAKE IS LUBRICATED WITH 80-90 W GEAR OIL WHEN MOUNTED PINION UP ONLY
4. ORIENT BEARING GREASE ZERK ON DRIVE TOWARD VALVE BANK COVER AND VALVE BLOCK AS SHOWN

VALVE BANK COVER (REF)

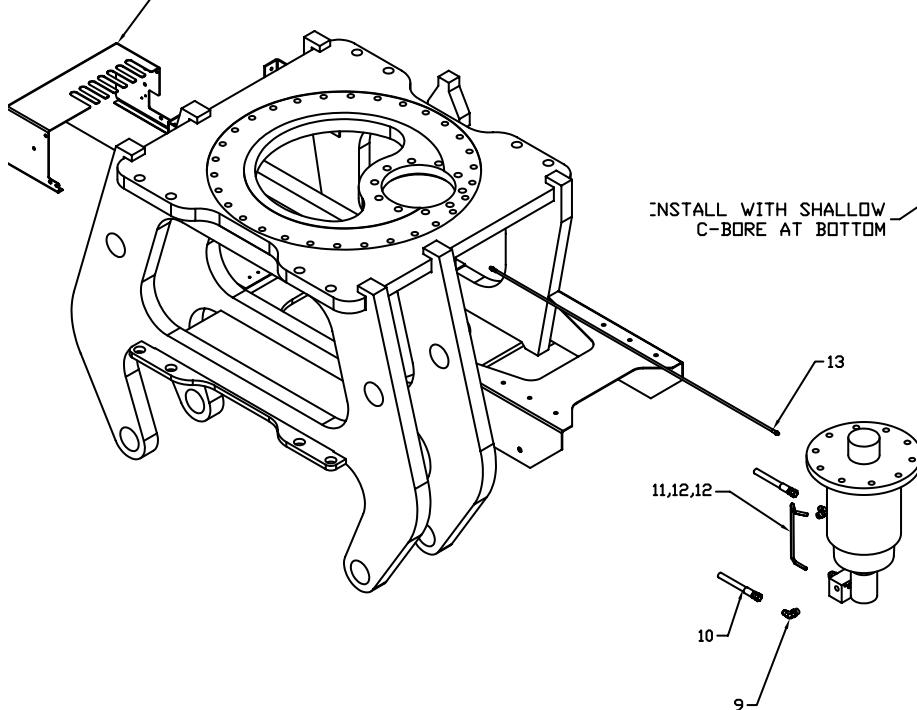

VALVE BLOCK PORT 'A' CONNECTS TO 'A' SIDE OF VALVE BANK.
 VALVE BLOCK PORT 'B' CONNECTS TO 'B' SIDE OF VALVE BANK

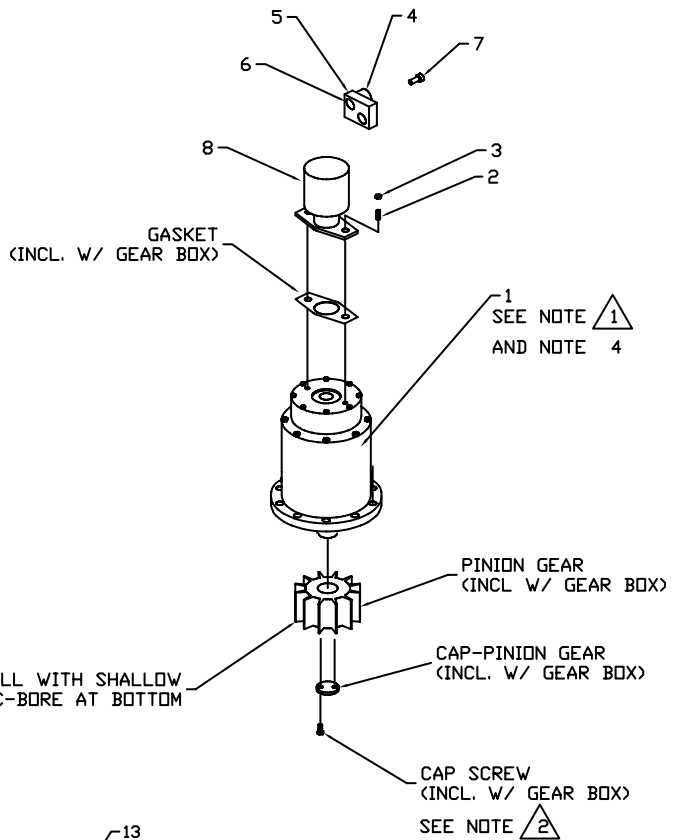

INSTALL WITH SHALLOW C-BORE AT BOTTOM

SEE NOTE 1 AND NOTE 4

SEE NOTE 2

GEAR BOX (70056564)

1.	43502	GEAR HOUSING	1
2.	42756	SHAFT, OUTPUT	1
3.	70146129	BEARING, CUP	1
4.	70146130	BEARING, CONE	1
5.	70146131	OIL SEAL	1
6.	70146132	BEARING, CUP	1
7.	70146133	BEARING, CONE	1
8.	70146134	LOCKNUT, BEARING	1
9.	70146135	LOCKWASHER, BEARING	1
10.	41742	GEAR, SUN, OUTPUT	1
11.	70146137	RACE	2
12.	42773	GEAR, SUN, INPUT	1
13.	4138	INPUT GEAR SET	1
14.	4176	GEAR SET, OUTPUT	1
15.	42897	HOUSING, BRAKE	1
16.	939261	CAPSCREW M10/12	8
17.	20913	WASHER	2
18.	23543	CAPSCREW	2
19.	33561	PROTECTOR	1
20.	70146146	PLUG, O-RING	2
21.	70146147	CAPLUG	1
23.	21128	FITTING, GREASE ZERK	1
24.	70146148	PINION GEAR	1
25.	42760	SPACER	1
26.	20524	CAPSCREW	2
27.	42712	COVER, BRAKE	1
28.	30076	CAPSCREW	8
29.	70146153	DRIVER, BRAKE	1
30.	70146154	SPRING, BRAKE	6
31.	70146155	O-RING	1
32.	70146156	O-RING	1
33.	70146157	O-RING	1
34.	70146158	O-RING	1
35.	70146159	O-RING	1
36.	70146160	DISC, FRICTION	4
37.	70146161	PLATE, STATOR	6
38.	70146162	O-RING	1
39.	13050	BREATHER	1
40.	70146164	BEARING	1
41.	70146165	PISTON, BRAKE	1
42.	70146166	RETAINING RING	1
43.	70146167	RETAINING RING	1
44.	70146168	RETAINING RING	1
45.	42752	PLUG, O-RING, SPECIAL	1
46.	70146170	CAPLUG	1
47.	70146171	PISTON, BRAKE	1
48.	70146172	SPACER	1

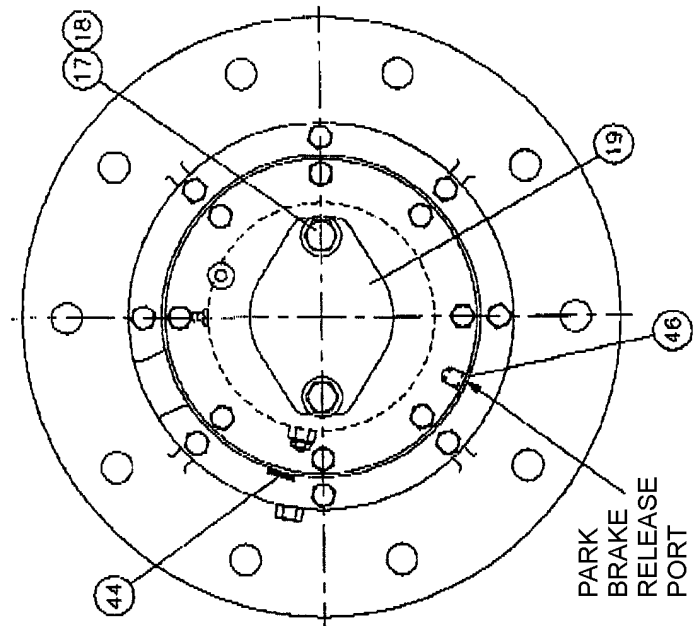
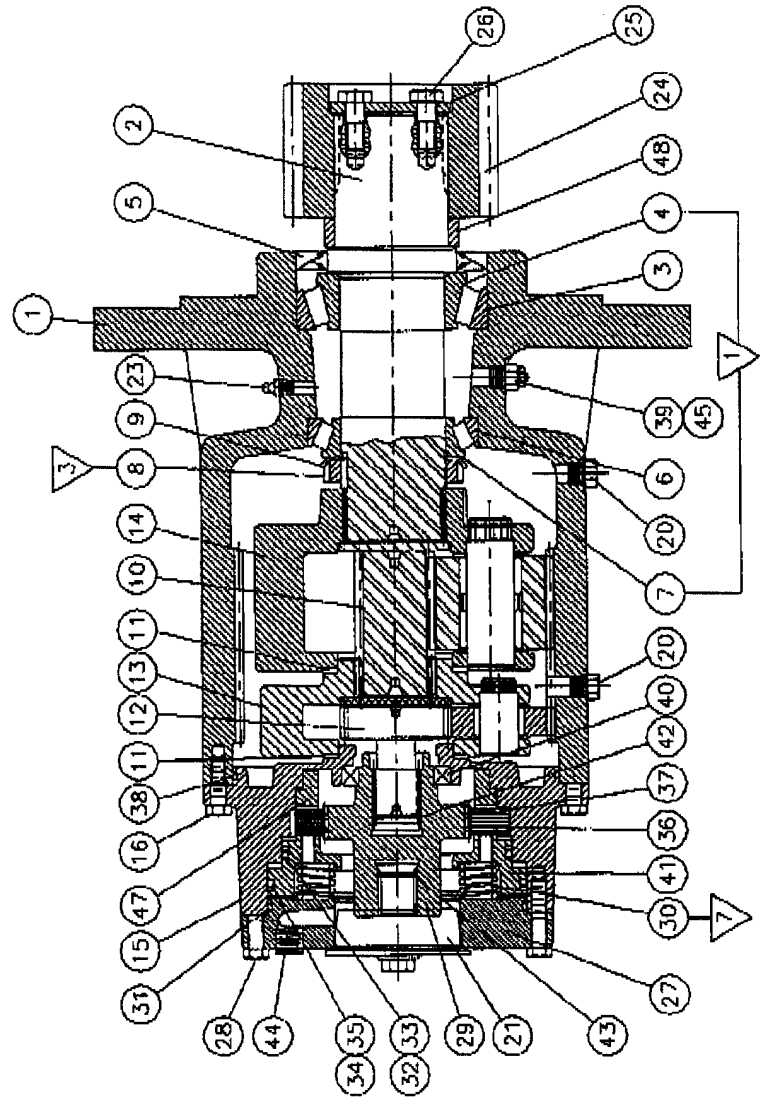

HYDRAULIC KIT - RESERVOIR (99901235)

1.51715011	RESERVOIRASM	1
2.73054232	BALL VALVE 1-1/4NPT	2
3.72531550	BARB NIPPLE 1-1/4MPT 1-1/4	1
4.73052012	RETURN FILTER 100MESH	2
5.72053578	REDUCER BUSHING 1-1/2 1NPT	2
6.72531430	ELBOW 1MPT #16MJIC 90°	1
7.72053680	ADAPTER 1MPT #16MJIC	1
8.76391527	RUBBER BUMPER	6
9.70144807	SPRING	6
10.72060055	CAP SCR 3/8-16X3-1/2 HHGR5	6
11.72063003	WASHER 3/8 WRT	12

12.72063005	WASHER 1/2 WRT	6
13.72060037	CAP SCR 5/16-18X4 HHGR5 (WAS 72060031)	3
14.51715851	VALVEBANKASM	1
15.72062001	NUT 5/16-18 HEX	3
16.72053607	TEE 1-1/2NPT	1
17.72531551	BARB NIPPLE 1-1/4MPT 1-1/2	1
18.72053211	PIPE NIPPLE 1-1/4NPT X CLOSE	4
19.72531135	STREET ELBOW 1-1/4NPT 90°	2
20.72532560	ADAPTER 1-1/2MSTR 1-1/2FPT	1
21.72053251	PIPE NIPPLE 1-1/2NPT X CLOSE	1
22.71410697	SPRING	3

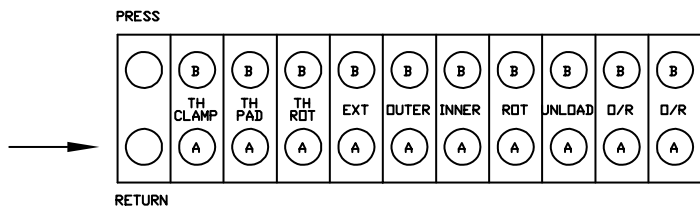
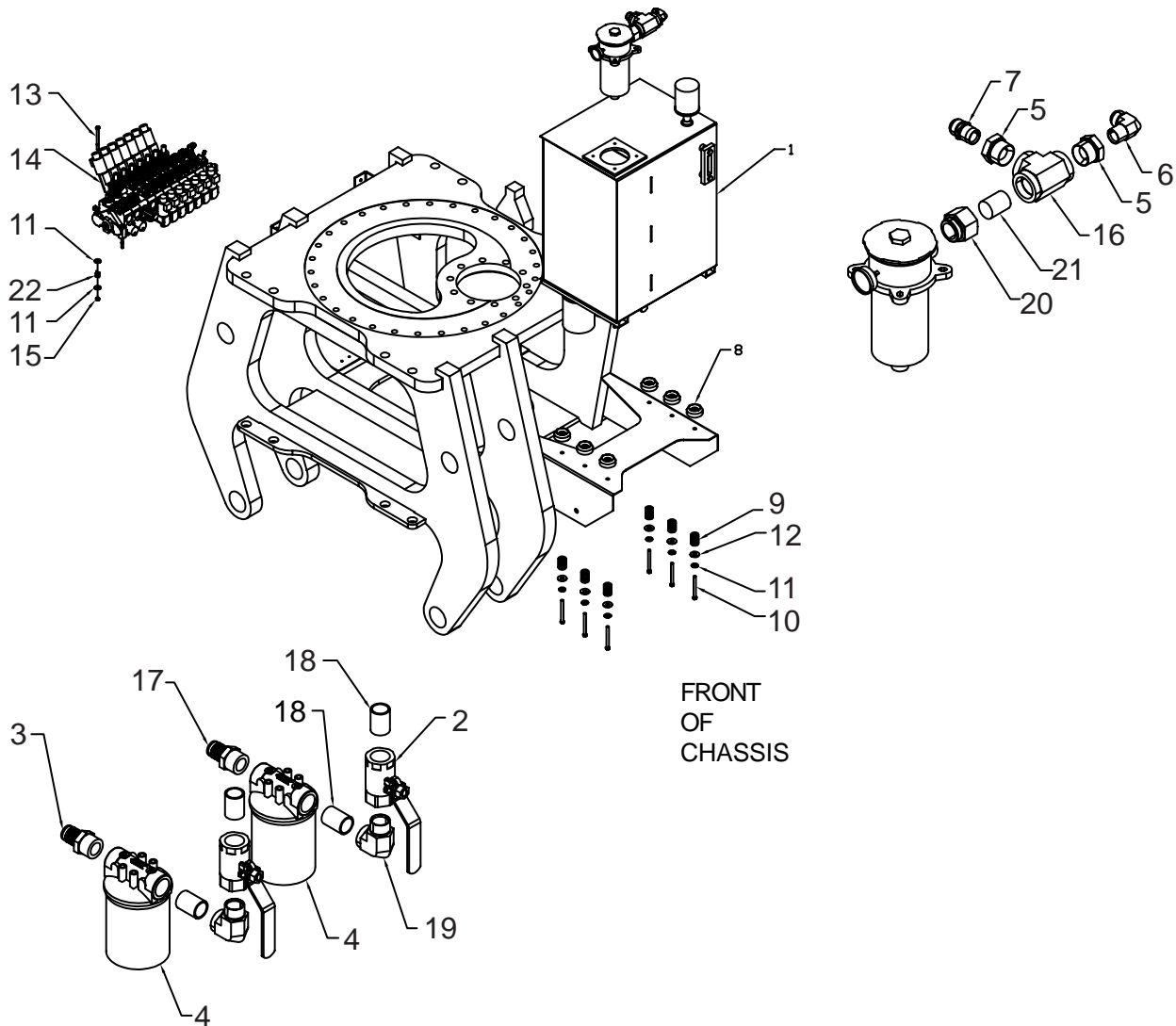

VALVE BANK ORIENTATION

RESERVOIR ASM (51715011)

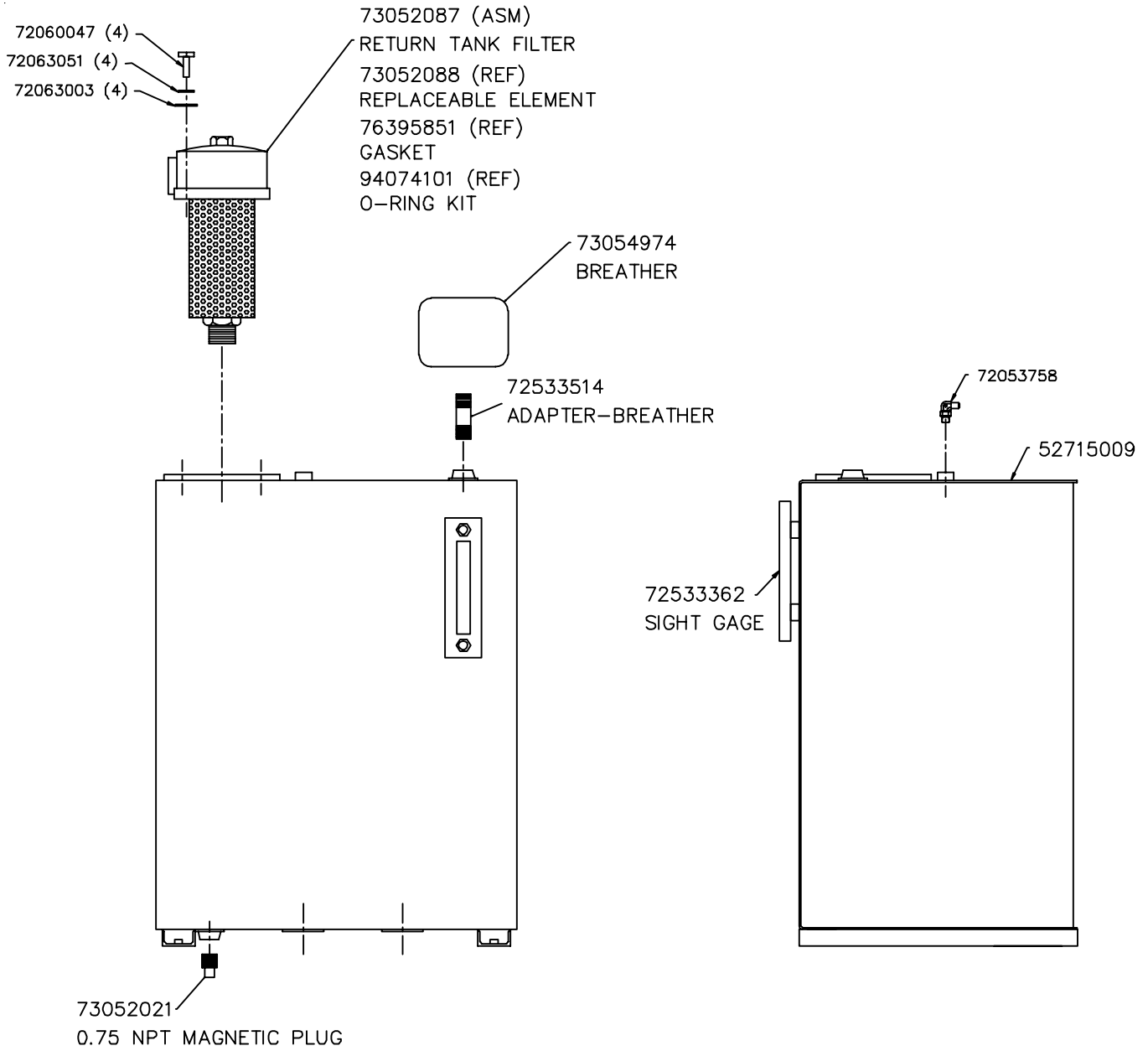

HYD KIT-INNER CYLINDER (99903149)

- | | | |
|-------------|-----------------------|------|
| 1. 51395413 | HOSE-FF .50X59 #8#8 | 2REF |
| 2. 51395727 | HOSE-FJ .50X14 #8#8 | 2REF |
| 3. 72533566 | SWIVEL-INLINE #8MJIC | 2REF |
| 4. 72532358 | ADAPTER #8MSTR #8MJIC | 2REF |

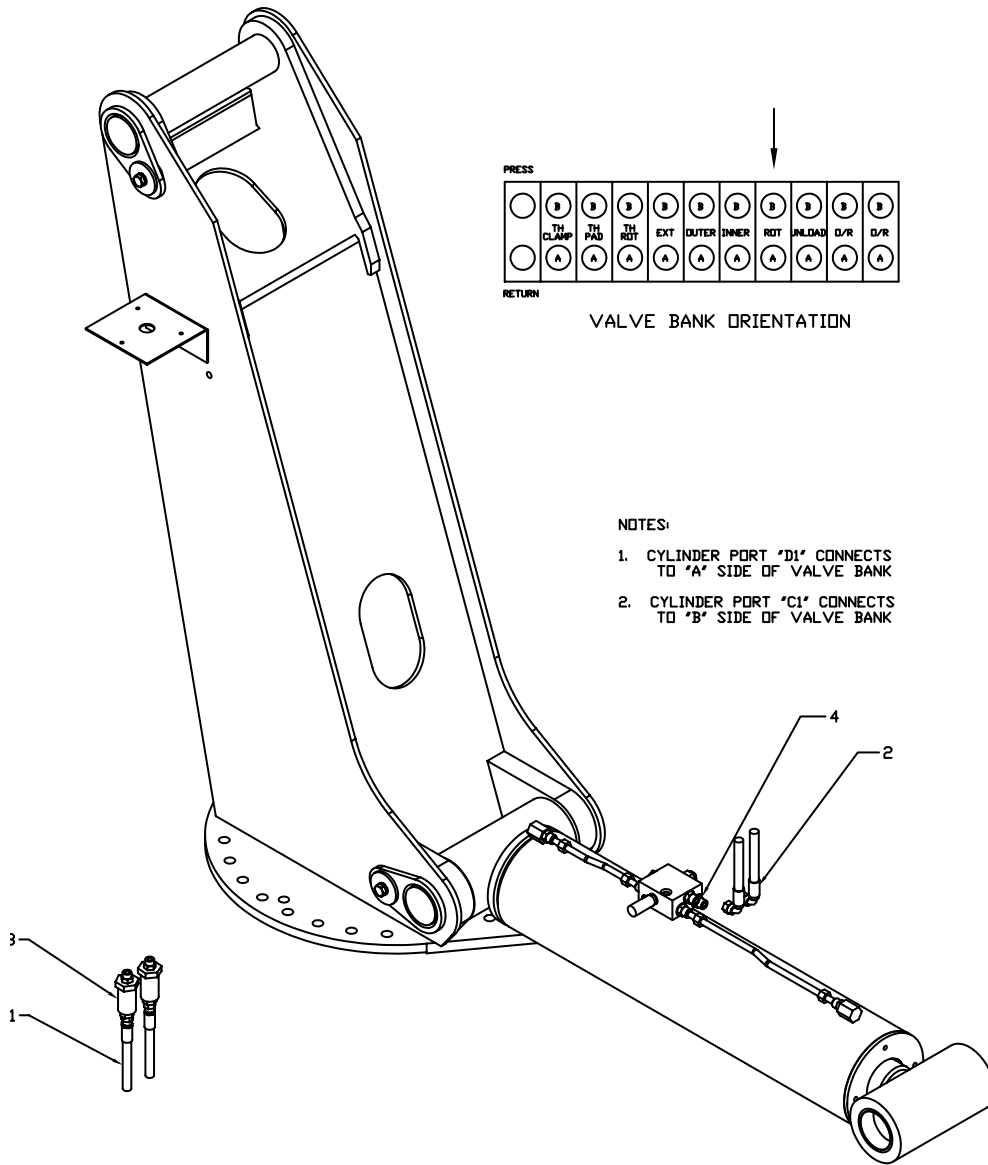

VALVE BANK ORIENTATION

NOTES:

1. CYLINDER PORT 'D1' CONNECTS TO 'A' SIDE OF VALVE BANK
2. CYLINDER PORT 'C1' CONNECTS TO 'B' SIDE OF VALVE BANK

HYD KIT-OUTER CYLINDER (99903150)

- | | | |
|-------------|-----------------------|------|
| 1. 72533566 | SWIVEL-INLINE #8MJIC | 2REF |
| 2. 72532358 | ADAPTER #8MSTR #8MJIC | 2REF |
| 3. 51395413 | HOSE-FF .50X59 #8#8 | 2REF |
| 4. 51395731 | HOSE-FF .50X85 #8#8 | 2REF |

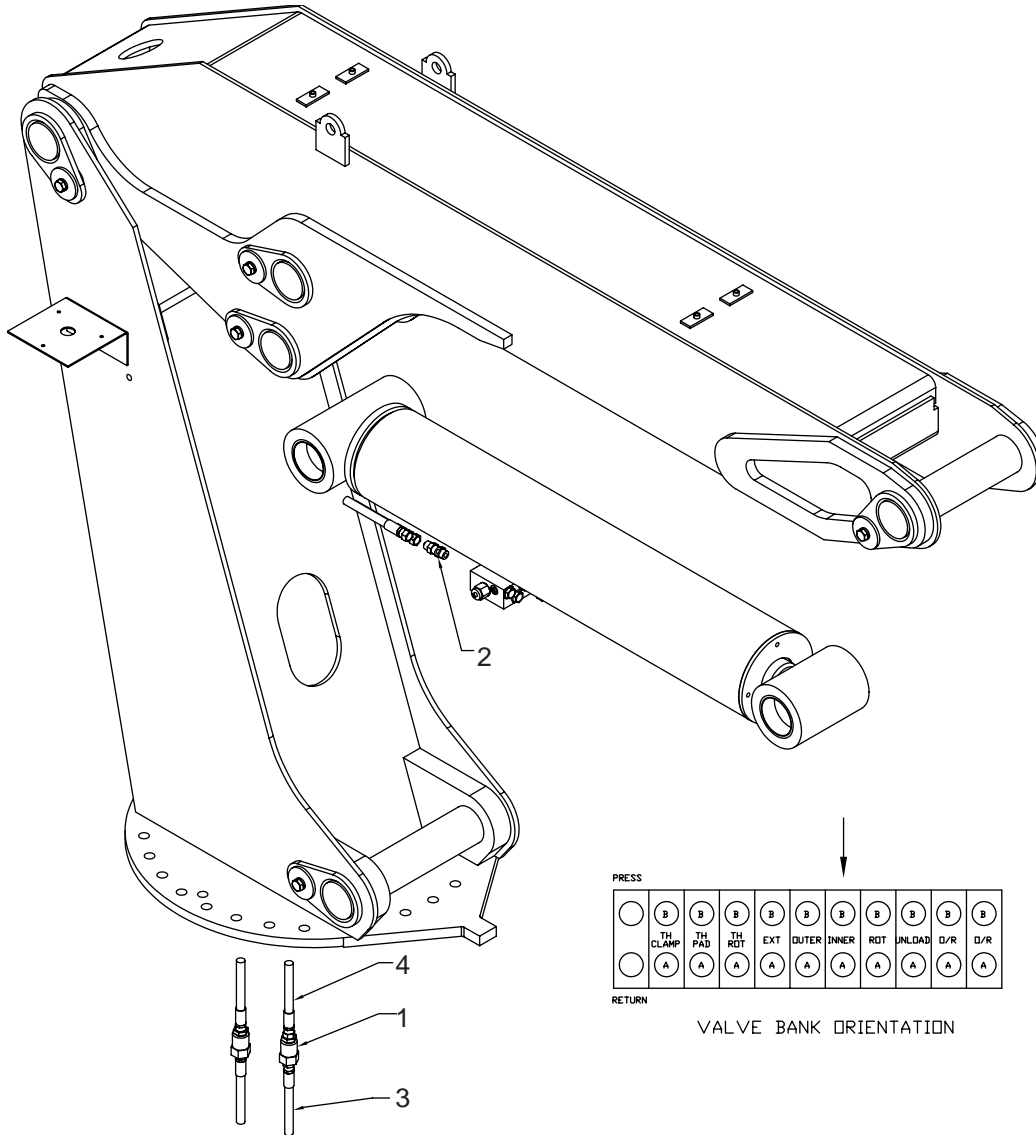

- NOTES:**
1. CYLINDER PORT "D2" CONNECTS TO "A" SIDE OF VALVE BANK.
 2. CYLINDER PORT "C2" CONNECTS TO "B" SIDE OF VALVE BANK

HYD KIT-EXT CYLINDER (99903151)

- | | | |
|-------------|---------------------------|------|
| 1. 72532358 | ADAPTER #8MSTR #8MJIC | 2REF |
| 2. 51395733 | HOSE-FF .50X87 #8#12 | 2REF |
| 3. 60350093 | SLEEVE-HOSE AS | 1 |
| 4. 72532658 | ELBOW #8MJIC/90/#8FJIC SW | 2REF |

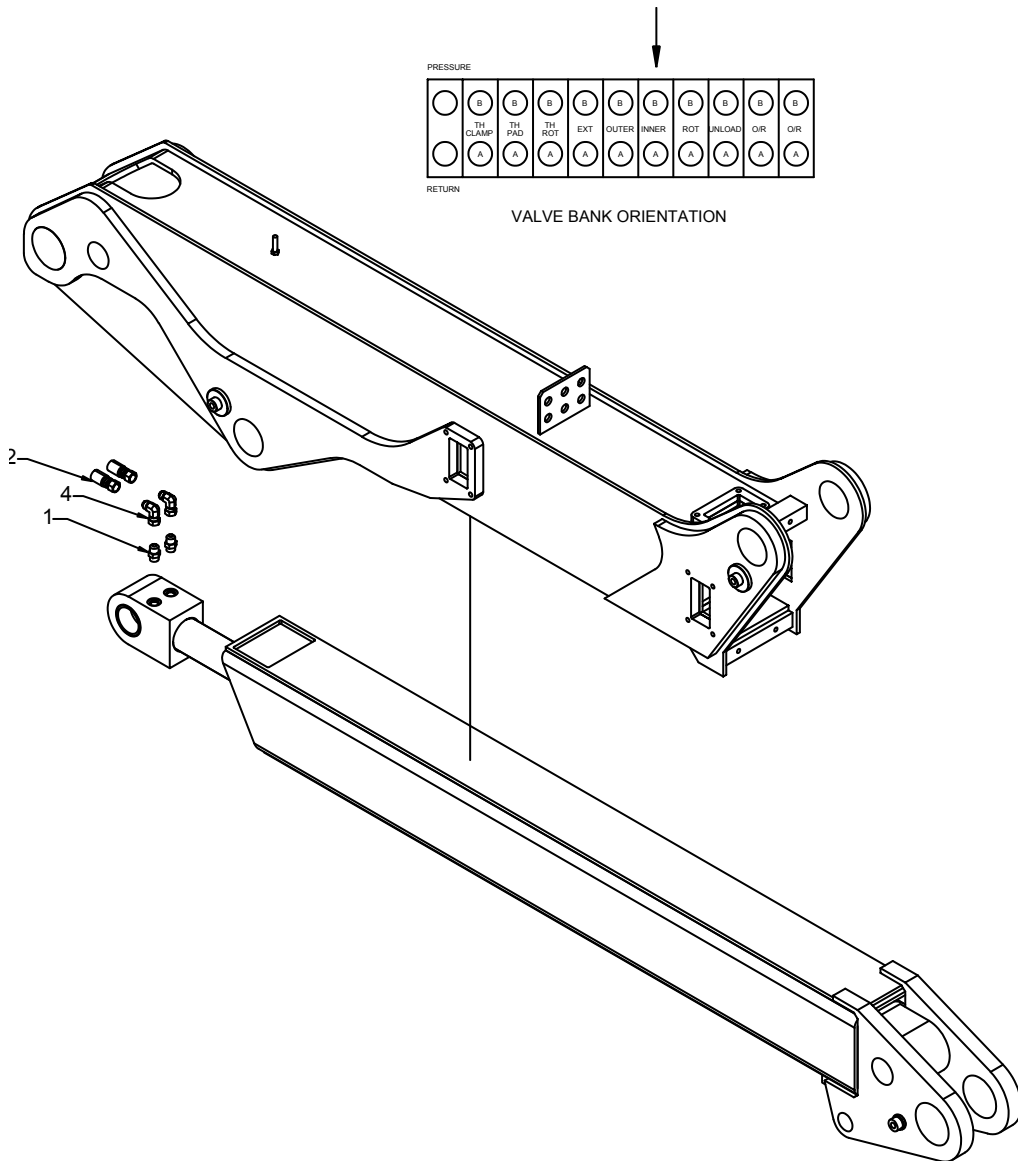

NOTES:

1. CYLINDER PORT "E" CONNECTS TO "A" SIDE OF VALVE BANK.
2. CYLINDER PORT "R" CONNECTS TO "B" SIDE OF VALVE BANK.
3. RUN HOSES (#2) THRU SLEEVE (#3).

HYD KIT-BULKHEAD LAYOUT (99903152)

1. 72533579	DISC COUPLER 1/2 FF-501-8FP	6REF
2. 72533580	DISC COUPLER 1/2 FF-502-8FP	6REF
3. 72533430	ADAPTER 1/2MPT #8MJIC BLKHD	6REF
4. 70146076	TUBEASM	8
5. 72060034	CAP SCR 5/16-18X3-1/4 HHGR5	4
6. 70034417	HOSE CLAMP 3/4	8
7. 70144819	COVER PLATE	4
8. 72533566	SWIVEL-INLINE #8MJIC	6REF
9. 51395413	HOSE-FF .50X59 #8#8	6REF
10. 51395735	HOSE-FF .50X83 #8#12	6REF
11. 72053497	ADAPTER 1/2MPT #8MJIC	6REF
12. 60350092	SLEEVE 2-3/8 X 78	2
13. 51395733	HOSE-FF 1/2 X 87.00 OAL (8-12)	6REF
14. 60350094	SLEEVE 2-3/8 X 70	2

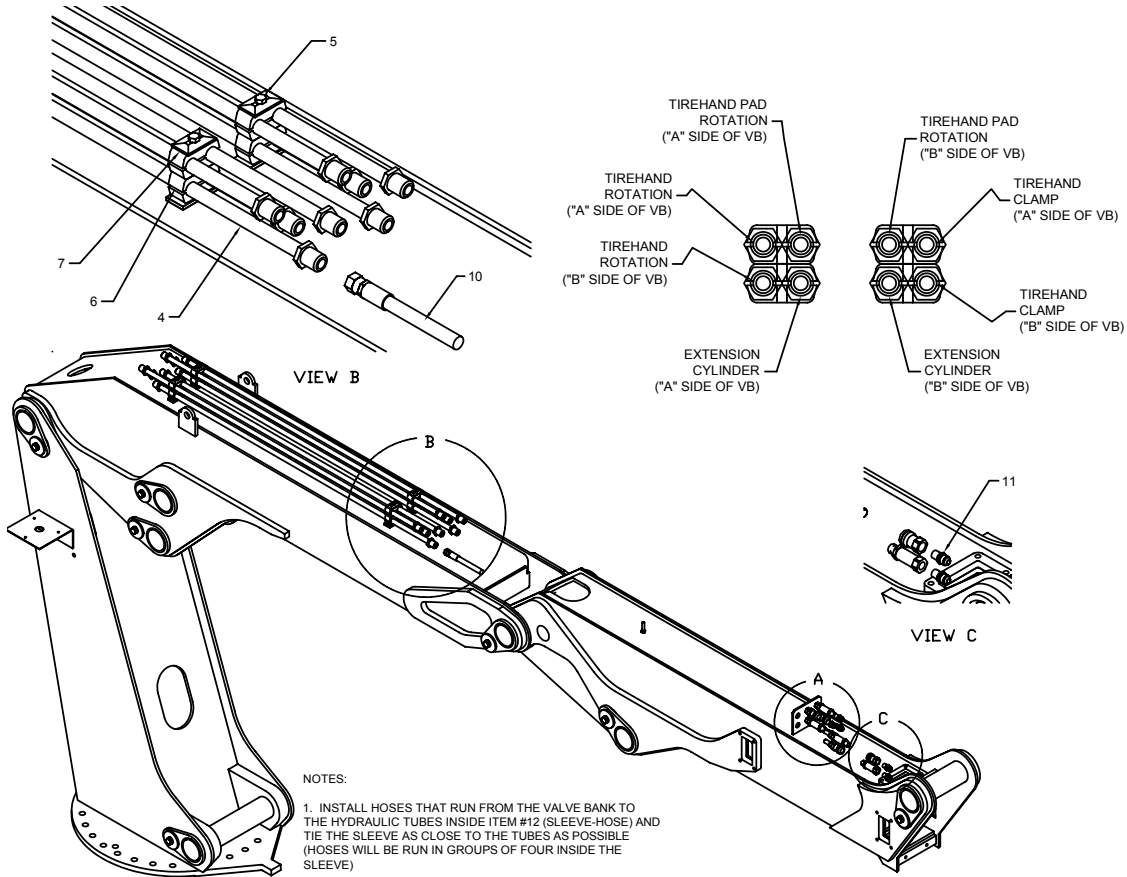

- NOTES:
1. INSTALL HOSES THAT RUN FROM THE VALVE BANK TO THE HYDRAULIC TUBES INSIDE ITEM #12 (SLEEVE-HOSE) AND TIE THE SLEEVE AS CLOSE TO THE TUBES AS POSSIBLE (HOSES WILL BE RUN IN GROUPS OF FOUR INSIDE THE SLEEVE)
 2. WHEN ROUTING THE HOSES, HAVE THE HOSES COME OUT THE BOTTOM HOLE OF THE MAST AND UP THE BACK OF THE MAST (OUTSIDE.)
 3. INSTALL HOSES (#10) THAT RUN OUT TO THE BULKHEAD PLATE INSIDE OF SLEEVE (#14). (HOSES WILL BE RUN IN GROUPS OF 3.)

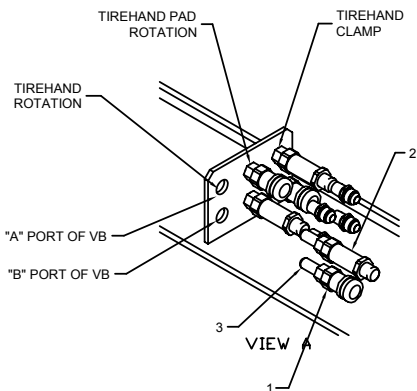
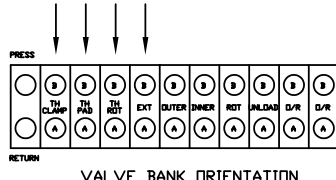
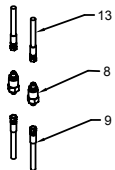

HYD KIT-OUTRIGGERS (99903153)

- | | | |
|-------------|-----------------------|------|
| 1. 72532358 | ADAPTER #8MSTR #8MJIC | 2REF |
| 2. 51395724 | HOSE-FI .50X51 #8#8 | 2REF |
| 3. 51395725 | HOSE-FI .50X84 #8#8 | 2REF |

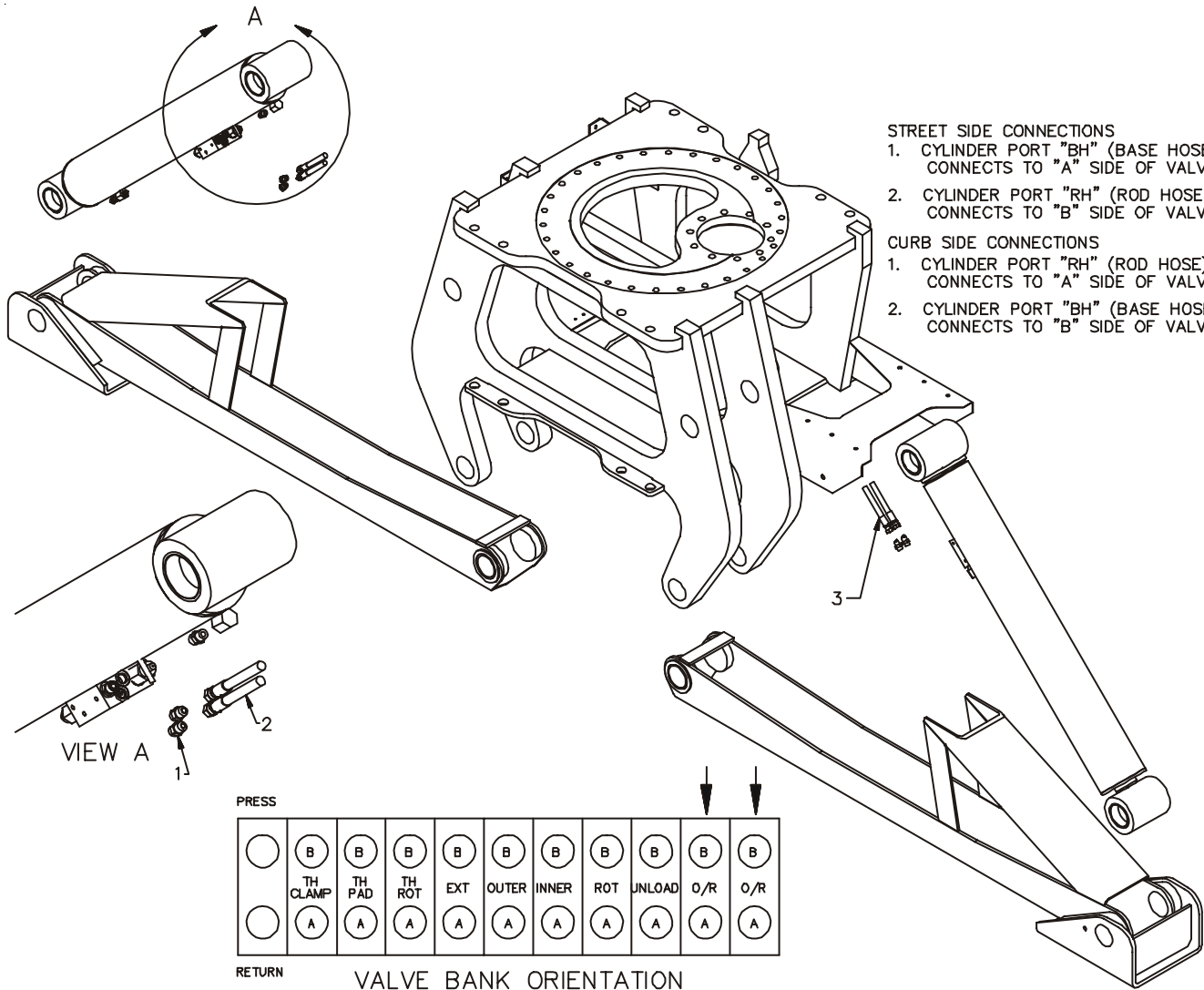

- STREET SIDE CONNECTIONS**
1. CYLINDER PORT "BH" (BASE HOSE)
CONNECTS TO "A" SIDE OF VALVE BANK
 2. CYLINDER PORT "RH" (ROD HOSE)
CONNECTS TO "B" SIDE OF VALVE BANK

- CURB SIDE CONNECTIONS**
1. CYLINDER PORT "RH" (ROD HOSE)
CONNECTS TO "A" SIDE OF VALVE BANK
 2. CYLINDER PORT "BH" (BASE HOSE)
CONNECTS TO "B" SIDE OF VALVE BANK

PRESS

○	B	B	B	B	B	B	B	B	B	B	B
	TH CLAMP	TH PAD	TH ROT	EXT	OUTER	INNER	ROT	UNLOAD	O/R	O/R	
○	A	A	A	A	A	A	A	A	A	A	
RETURN	VALVE BANK ORIENTATION										

↓ ↓

HYD KIT-SCHEMATIC (99903210)

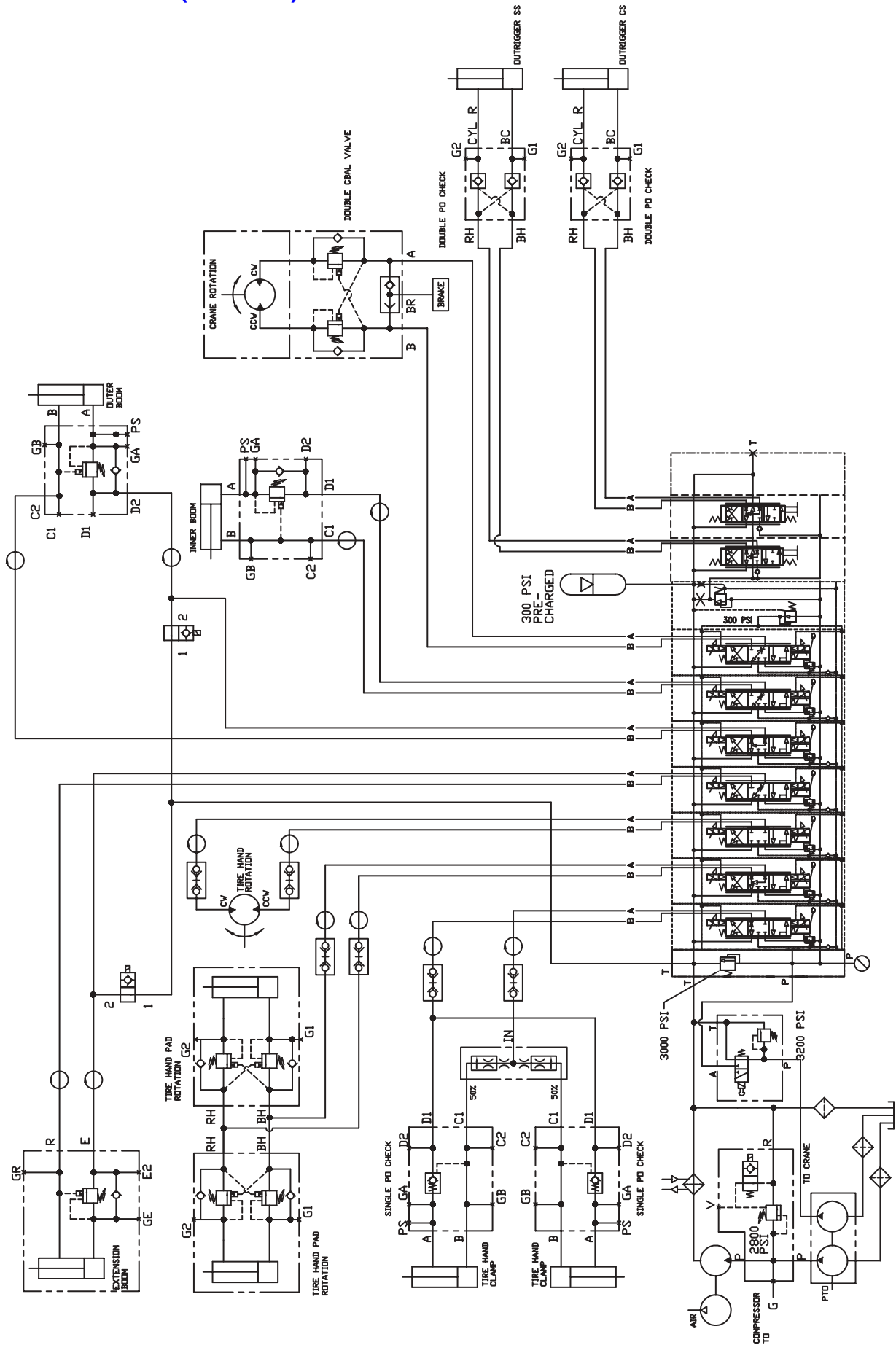

HYD KIT (91717986-2)

1. 72053497 ADAPTER 1/2MPT #8MJIC	6	25. 51395734 HOSE-FF .50X52 #8#12	2REF*
2. 72533566 SWIVEL-INLINE #8MJIC	12	26. 51395735 HOSE-FF .50X94 #8#12	6REF*
3. 72533579 DISC COUPLER 1/2NPT	3	36. 73054980 VALVE-SOLENOID	2
4. 72533643 NIPPLE #8 NON-SPILL	3	38. 72533650 TEE #8MSTR	3
5. 72533607 ADAPTER 1/2MPT #8MJIC BLKHD	6	39. 72053497 ADAPTER 1/2MPT #8MJIC	1
6. 72053763 ELBOW #8MSTR #8MJIC 90°	3	40. 72532775 ADAPTER #4MSTR #6MJIC	2REF
7. 72532358 ADAPTER #8MSTR #8MJIC	10	42. 72532560 ADAPTER 1-1/2MSTR 1-1/2FPT	1REF
9. 51715950 HOSE KIT (CRANE & TH) (INCL:10-21,22-29,31-33)	1	43. 72053251 PIPE NIPPLE 1-1/2NPT X CLOSE	1REF
11. 51395404 HOSE-FF .50X48 #8#8	2REF*	44. 72053607 TEE 1-1/2NPT	1REF
12. 51395413 HOSE-FF .50X59 #8#8	10REF*	45. 72053578 REDUCER BUSHING 1-1/2 1NPT	2REF
13. 51395429 HOSE-FF .50X45 #8#8	2REF*	46. 72053680 ADAPTER 1MPT #16MJIC	1REF
14. 51395722 HOSE-FI .63X73 #12#12	1REF*	47. 70733498 ACCUMULATOR	1
15. 51395723 HOSE-FJ 1X112 #20#16	1REF*	48. 72066507 MUFFLER CLAMP 2-1/4	1
16. 51395724 HOSE-FI .50X51 #8#8	2REF*	49. 51395932 HOSE-FJ .38X18.5 #6#6	1
17. 51395725 HOSE-FI .50X84 #8#8	2REF*	50. 72531430 ELBOW 1MPT #16MJIC 90°	1REF
18. 51395726 HOSE-FJ .50X25 #8#8	2REF*	51. 73055278 VALVE ASM - RELIEF/SOL	1REF
19. 51395727 HOSE-FJ .50X14 #8#8	2REF*	52. 51396300 HOSE-FF 3/4 X 35.00 OAL	1REF
20. 51395728 HOSE-JJ .50X12 #8#8	1REF*	53. 72533000 TEE-SWVL NUT RUN JIC 16	1REF
21. 51395729 HOSE-FI .50X16.5 #8#8	1REF*	54. 72053767 ELBOW-#12MSTR #12MJIC 90°	2REF
22. 70146107 TUBE ASM-ROTN	1REF	55. 72532366 ADPTR-#12MSTR #12MJIC	1REF
23. 51395731 HOSE-FF .50X85 #8#8	2REF*	56. 51396303 HOSE-FJ 3/4 X 61.00 OAL	1REF
24. 51395733 HOSE-FF .50X87 #8#12	8REF*	57. 72532971 ELBOW #16 MJIC #16FJIC SW	1REF

* PART OF ITEM 9, HOSE KIT.

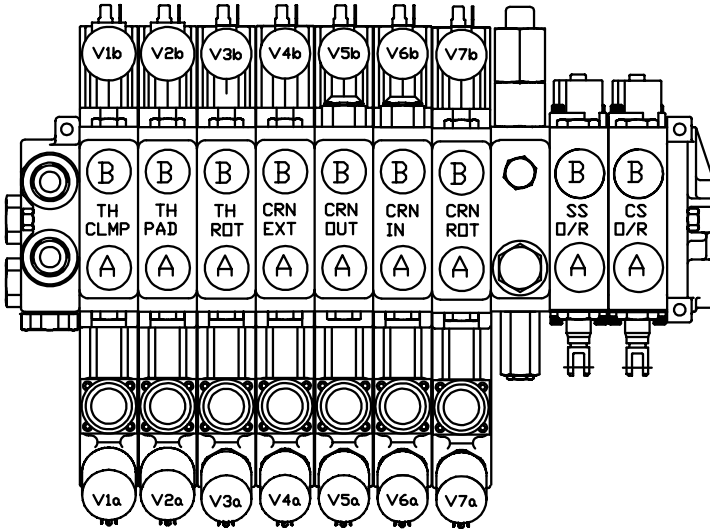

VALVE BANK ORIENTATION & RADIO HARNESS CONNECTIONS

NOTES:

- FOR DETAILED HYDRAULIC ASSEMBLY SEE THE FOLLOWING DRAWINGS; 99901234, 99901235, 99903055, 99903056, 99903149, 99903150, 99903151, 99903152, 99903153, 99903210, & 99903465

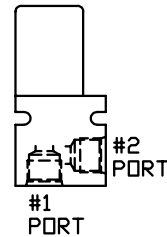

SOLENOID ORIENTATION

CONNECTS TO 'B' SIDE OF VALVE BANK
CONNECTS TO 'A' SIDE OF VALVE BANK

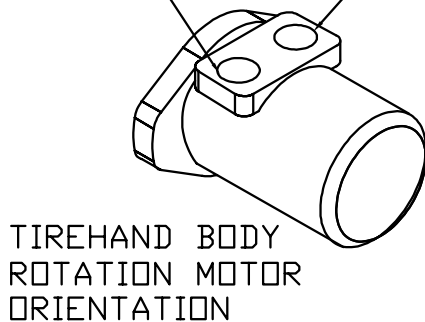

TIREHAND BODY ROTATION MOTOR ORIENTATION

USED ON:
 - 23516 UNITS WITH SERIAL NUMBER 23516021001 TO PRESENT
 - 14K160TH UNITS WITH SERIAL NUMBER 14K160TH021005 TO PRESENT

CONTROL KIT (90715855)

1. 52702016	CTRL ROD-F	1	7. 60025254	CTRL ROD	1
2. 52702018	CTRL ROD-M	1	8. 94731839	LINK & PIN KIT	1
3. 60122226	LINK-VB	1	9. 72066168	COTTER PIN .09X.75	1
4. 72062006	NUT 5/8-11 HEX	1	10. 72066338	CLEVIS PIN 5/16X1	1
5. 72062091	NUT 5/8-11 LOCK	1	11. 41715890	CTRL BOX ASM (SEE DWG)	1
6. 72060155	CAP SCR 5/8-11X3-1/2 HHGR5	1	12. 73733417	RADIO RMT KIT	1
			13. 72060046	CAP SCR 3/8-16X1 HHGR5	4
			14. 72062103	NUT 3/8-16 LOCK	4

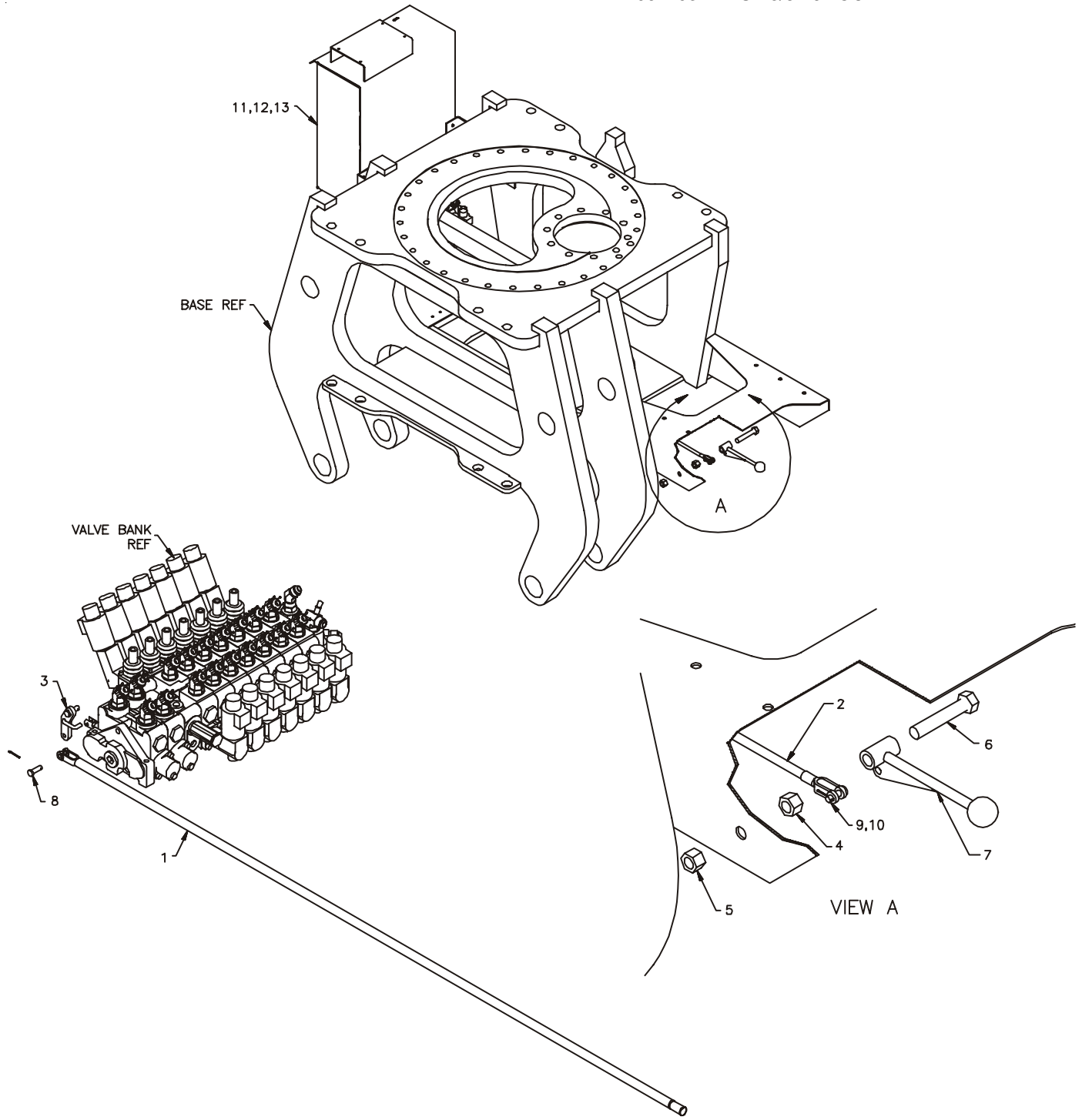

INSTALLATION KIT (93715856)

1.	52706660	SUPPORT 9.5	4
2.	60128960	CLAMP PLATE (WAS 60010665)	4
3.	60122550	STUD-TIE DOWN 1.25-7X48	8
4.	72062142	NUT 1.25-7 LOCK STL-INSERT	16
5.	72063067	WASHER 1.25 HI-STRNGTH	16
6.	60122834	BAR	4

BOTTOM VIEW

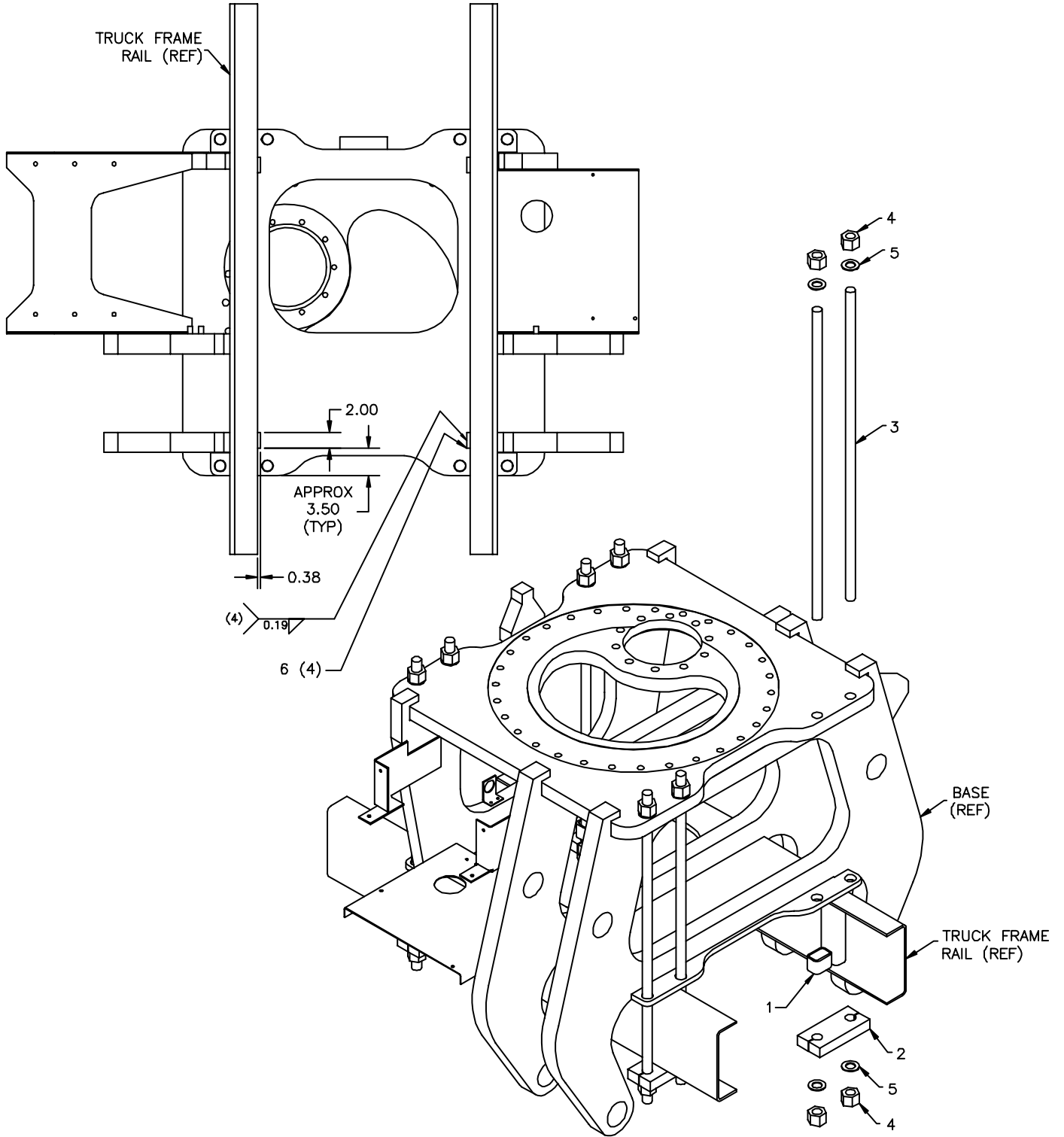

DECAL KIT-CRANE (95715871)

- 1. 70029252 IMT DIAMOND 2
- 2. 70391612 GREASE WKLY LH 5
- 3. 70392524 ROTATE/GREASE 2
- 4. 70394764 DANGER-5 COMBINED 2
- 5. 70392890 DANGER-STOW/UNFOLD 2
- 6. 70392863 DANGER-HOIST PERS 2
- 7. 70394096 DECAL-E-STOP 1
(WAS 70395788 DECAL-KILL SWITCH)
- 8. 70395701 MAX LIFT 2
- 9. 70395515 CAPACITY CHART-14K160TH 2
- 10. 70392864 DANGER-OUTRG STD CLEAR 2

- 11. 70392867 DANGER-OUTRG MOVING 2
- 12. 70392868 DANGER-CRANE LOADLINE 2
- 13. 70392213 CAUTION-WASH/WAX 1
- 14. 70392982 SERVICE & REPAIR 1
- 15. 70394189 LUBE RECOMMEND 1
- 16. 71039134 CAUTION-OIL LEVEL 1
- 17. 70395869 OP INSTR-DEPLOY OUTRG 2
- 18. 70395783 CONTROL-OUTRG RH 1
- 19. 70392108 SUCTION LINE 1
- 20. 70392109 RETURN LINE 1
- 21. 70392865 DANGER-ELEC HZD-LG 4
- 22. 70392891 DANGER-DRIVELINE 2
- 23. 71302365 ALIGN CRANE-ROTATE 1
- 24. 70392889 DANGER-RC ELECTROCUTION 1
- 25. 70396301 DECAL - 23516 CONTROL 1

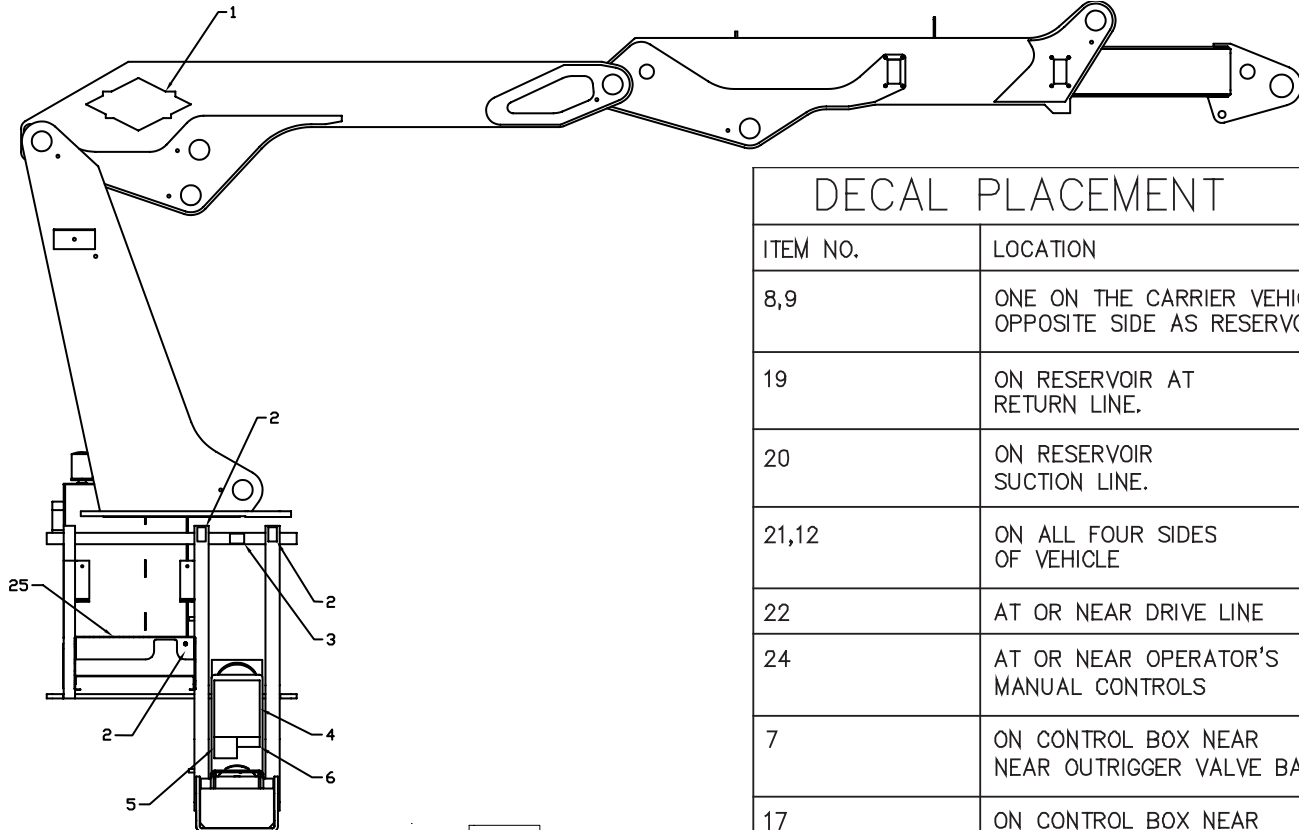

DECAL PLACEMENT	
ITEM NO.	LOCATION
8,9	ONE ON THE CARRIER VEHICLE OPPOSITE SIDE AS RESERVOIR
19	ON RESERVOIR AT RETURN LINE.
20	ON RESERVOIR SUCTION LINE.
21,12	ON ALL FOUR SIDES OF VEHICLE
22	AT OR NEAR DRIVE LINE
24	AT OR NEAR OPERATOR'S MANUAL CONTROLS
7	ON CONTROL BOX NEAR NEAR OUTRIGGER VALVE BANK
17	ON CONTROL BOX NEAR EMERGENCY STOP SWITCH

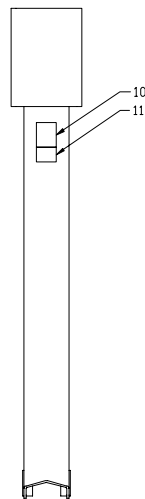

OUTRIGGER LEG
(BOTTOM SIDE IS SHOWN)

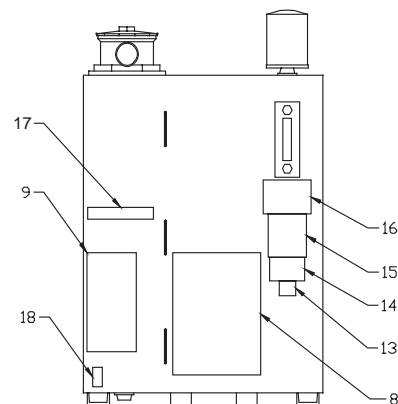

RESERVOIR

RADIO REMOTE KIT (73733417)

USED ON COM42K1001 WITH CRANE 14K160TH2K1001
AND COM42K1002 WITH CRANE 14K160TH2K1002 ONLY

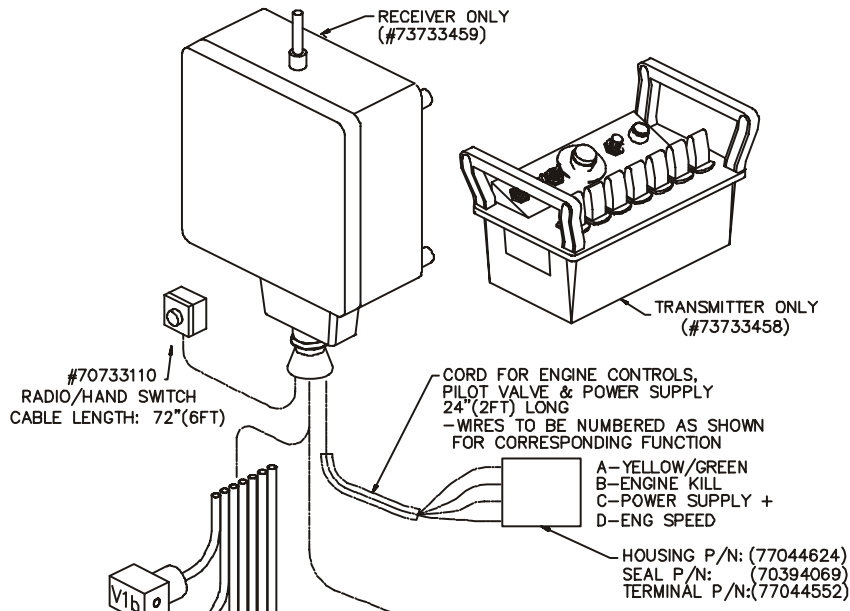

CABLE LENGTHS—
120" (10FT) W/
"DIN" CONNECTORS
ATTACHED

NOTE: Your transmitter may be different than shown.

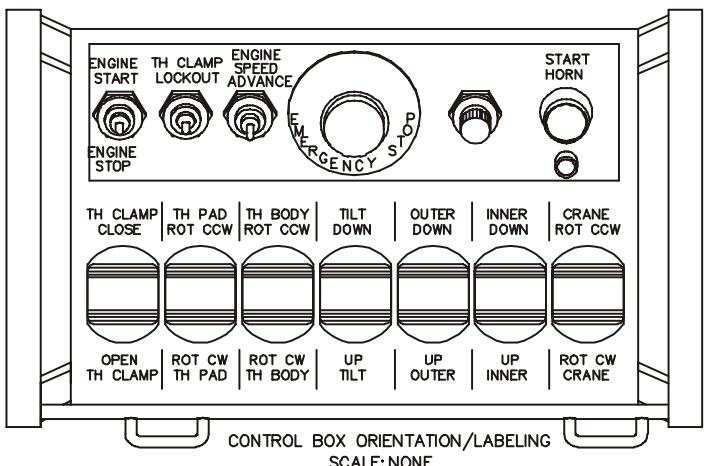

CONTROL BOX ORIENTATION/LABELING
SCALE: NONE

LABELING CHART		
*ALL CONNECTORS WILL BE SET UP AND LABELED ACCORDINGLY:		CABLE LENGTH
LABEL	CONTROLLED FUNCTION	
V1a	TIRE HAND CLAMP - OPEN	120"
V1b	TIRE HAND CLAMP - CLOSE	120"
V2a	TIRE HAND PAD ROT. - CW	120"
V2b	TIRE HAND PAD ROT. - CCW	120"
V3a	TIRE HAND BODY ROT. - CW	120"
V3b	TIRE HAND BODY ROT. - CCW	120"
V4a	TILT - UP	120"
V4b	TILT - DOWN	120"
V5a	OUTER CYLINDER EXTEND - UP	120"
V5b	OUTER CYLINDER RETRACT - DOWN	120"
V6a	INNER CYLINDER EXTEND - UP	120"
V6b	INNER CYLINDER RETRACT - DOWN	120"
V7a	CRANE ROTATION - CW	120"
V7b	CRANE ROTATION - CCW	120"

NOTES:

- BATTERY CHARGER - #70733109 (NOT SHOWN)
-(2) BATTERIES - #77042083 (NOT SHOWN)
- SOLENOID ACTUATOR SPECIFICATIONS:
-12VDC OPERATING VOLTAGE
-7.5 OHMS PROPORTIONAL COIL RESISTANCE @ 68F (20°C)
-6.5 OHMS ON-OFF COIL RESISTANCE
-PWM, 50 HZ FREQUENCY SIGNAL
- TH CLAMP LOCKOUT REQUIRED FOR ACTIVATION OF CLAMP PADDLE
-SWITCH TO BE MOMENTARY
- OVERALL APPEARANCE OF TRANSMITTER MAY DIFFER.
SWITCHES AND PADDLES TO BE LABELED AS SHOWN.

KIT-RADIO RMT-NOVA (73733481)

NOTE: Your transmitter may be different than shown.

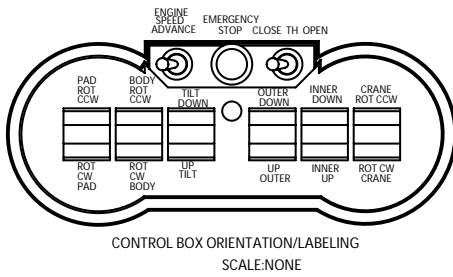

NOTES:

- BATTERY CHARGER - #70733290 (NOT SHOWN)
- (2) BATTERIES - #77042085 (NOT SHOWN)
- GREEN SOLENOID ACTUATOR SPECIFICATIONS:
- 12VDC OPERATING VOLTAGE
- 7.5 OHMS PROPORTIONAL COIL RESISTANCE @ 68° F (20° C)
- 6.5 OHMS ON-OFF COIL RESISTANCE
- PWM, 50 HZ FREQUENCY SIGNAL
- TH CLAMP LOCKOUT REQUIRED FOR ACTIVATION OF CLAMP PADDLE
- SWITCH TO BE MOMENTARY
- OVERALL APPEARANCE OF TRANSMITTER MAY DIFFER.
SWITCHES AND PADDLES TO BE LABELED AS SHOWN.

LABELING CHART		
*ALL CONNECTORS WILL BE SET UP AND LABELED ACCORDINGLY:		CABLE LENGTH
LABEL	CONTROLLED FUNCTION	
V1a	TIRE HAND CLAMP - OPEN	120"
V1b	TIRE HAND CLAMP - CLOSE	120"
V2a	TIRE HAND PAD ROT. - CW	120"
V2b	TIRE HAND PAD ROT. - CCW	120"
V3a	TIRE HAND BODY ROT. - CW	120"
V3b	TIRE HAND BODY ROT. - CCW	120"
V4a	TILT - UP	120"
V4b	TILT - DOWN	120"
V5a	OUTER CYLINDER EXTEND - UP	120"
V5b	OUTER CYLINDER RETRACT - DOWN	120"
V6a	INNER CYLINDER EXTEND - UP	120"
V6b	INNER CYLINDER RETRACT - DOWN	120"
V7a	CRANE ROTATION - CW	120"
V7b	CRANE ROTATION - CCW	120"

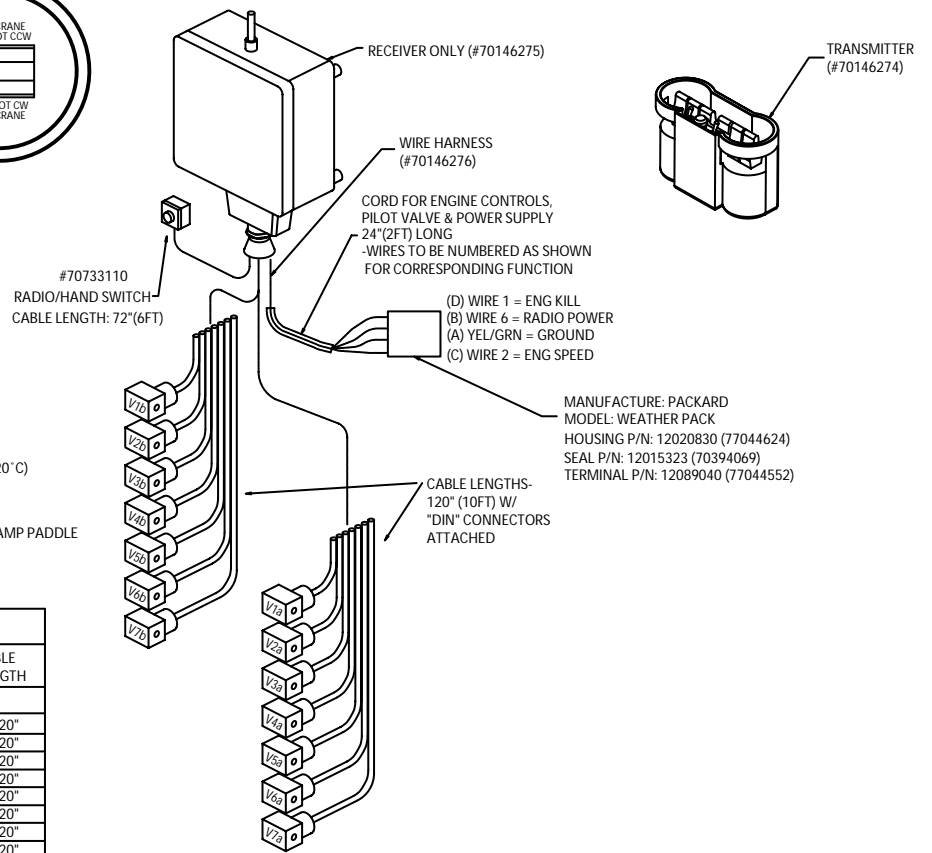

WIRING SCHEMATIC - CHASSIS & CRANE (99903201-1) (THRU 8/02)

USED ON:
 14K160TH UNITS WITH
 SERIAL NUMBERS
 14K160TH2K1001
 THROUGH
 14K160TH021002.

(NOTE: Body wiring section, shown on next page, connects here.)

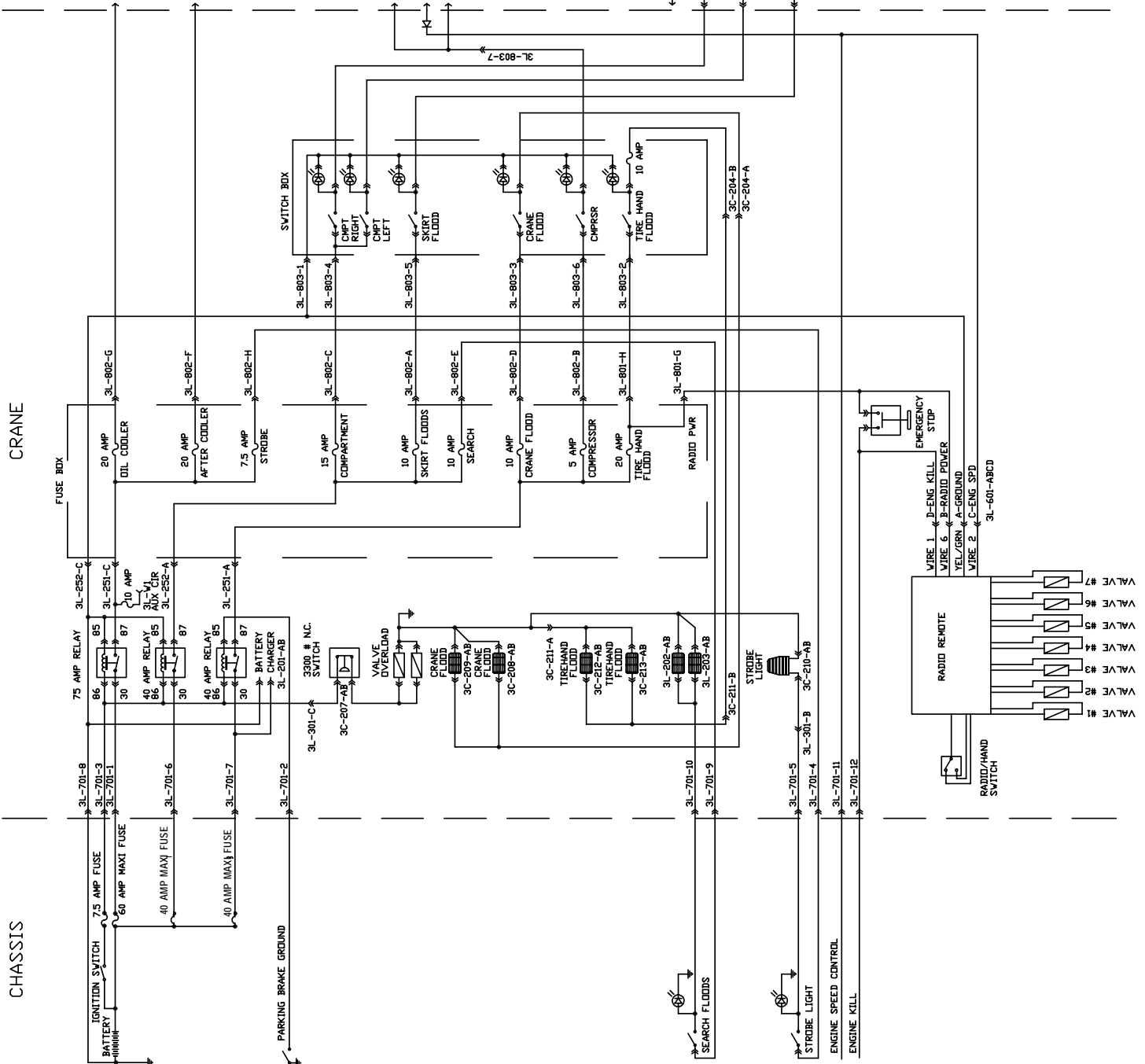

WIRING SCHEMATIC - BODY (99903201-1) (THRU 8/02)

CONTINUED ON NEXT PAGE

USED ON:
14K160TH UNITS WITH
SERIAL NUMBERS
14K160TH2K1001
THROUGH
14K160TH021002.

BODY

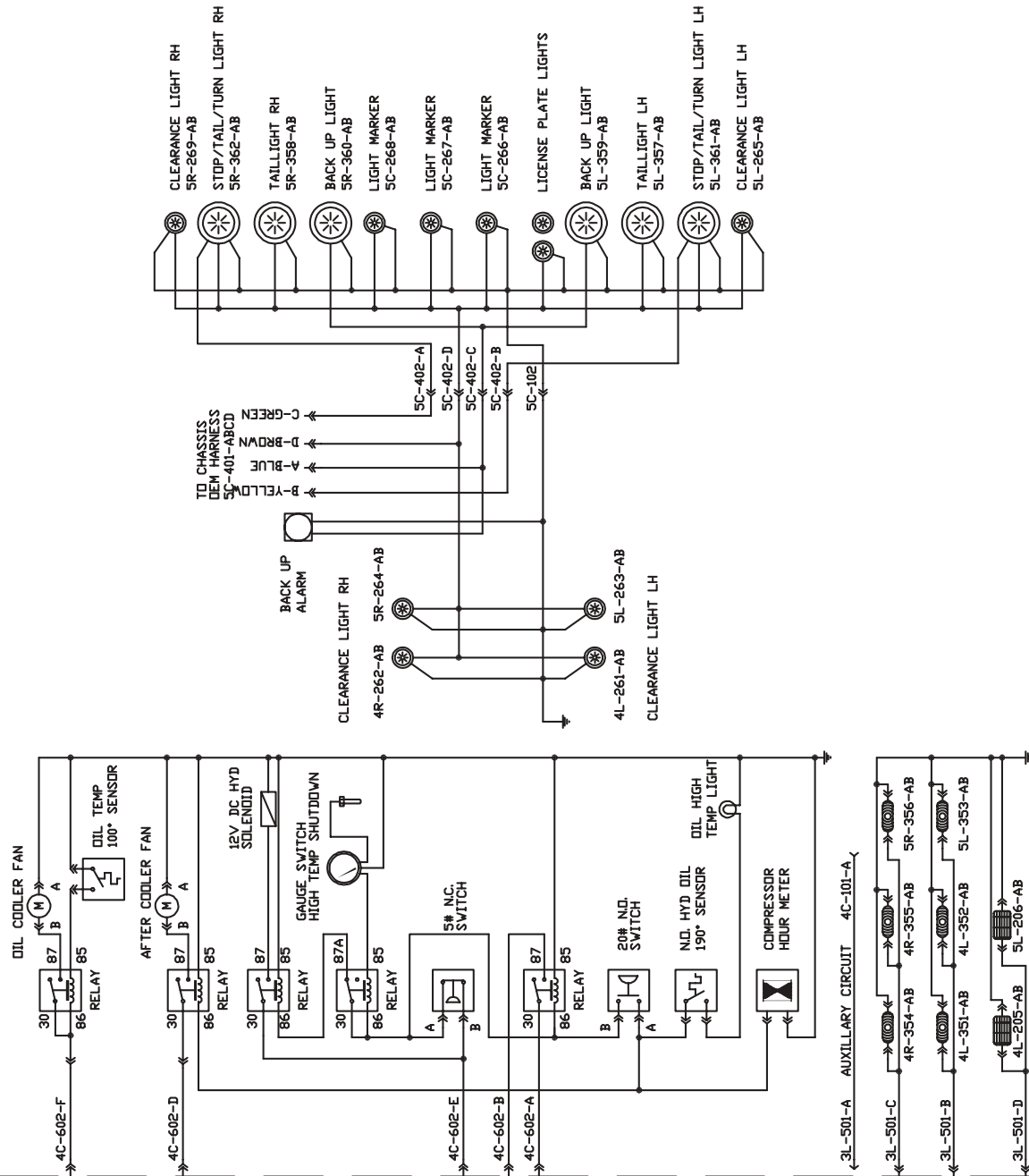

(NOTE: Chassis wiring section, shown on previous page, connects here.)

ELECTRICAL SCHEMATIC - CHASSIS- DUMP SYSTEM (99903557-1) (EFF. 9/02)

USED ON:
 - 23516 UNITS WITH SERIAL NUMBER 23516021001 TO PRESENT
 - 14K160TH UNITS WITH SERIAL NUMBER 14K160TH021003 TO PRESENT

NOTE: BODY WIRING, SHOWN ON NEXT PAGE, BEGINS HERE

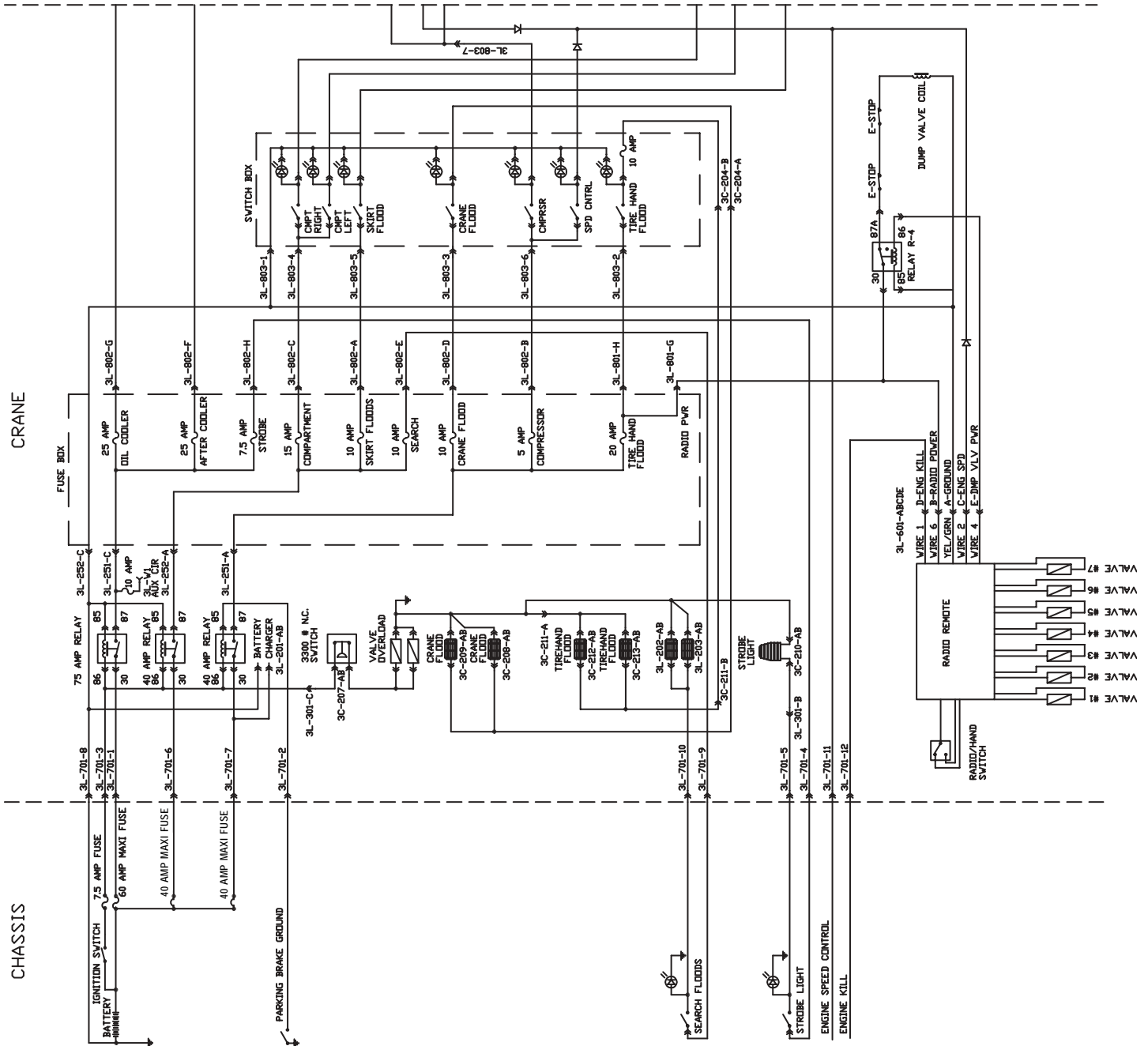

ELECTRICAL SCHEMATIC - BODY- DUMP SYSTEM (99903557-1) (EFF. 9/02)

USED ON:
 - 23516 UNITS WITH SERIAL NUMBER
 23516021001 TO PRESENT
 - 14K160TH UNITS WITH SERIAL NUMBER
 14K160TH021003 TO PRESENT

BODY

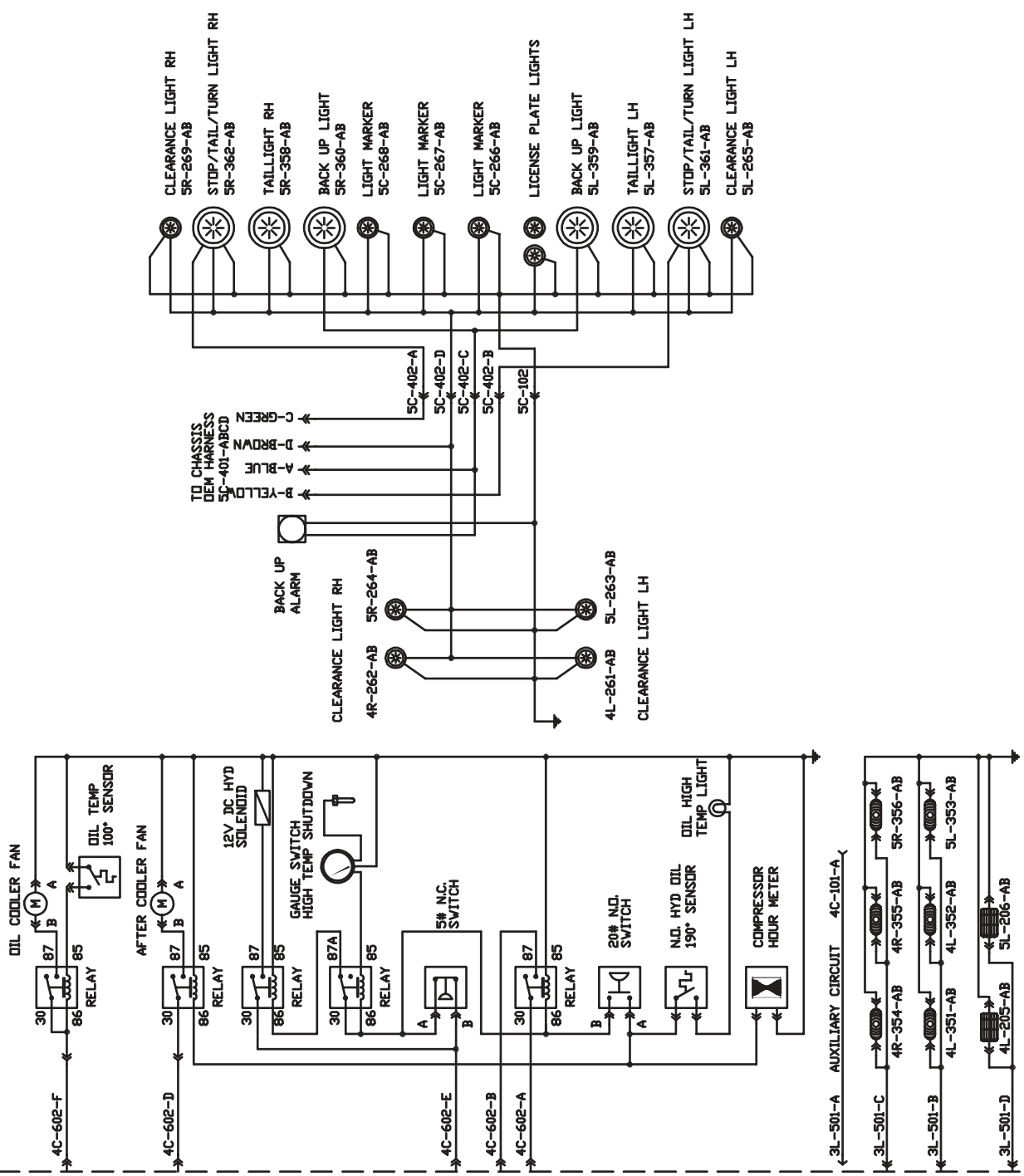

NOTE: CHASSIS WIRING, SHOWN ON PREV. PAGE, BEGINS HERE

ELECTRICAL SCHEMATIC - COMMANDER IV W/DUMP SYSTEM & SPEED CONTROL (99903557-2) (EFF. 9/02)

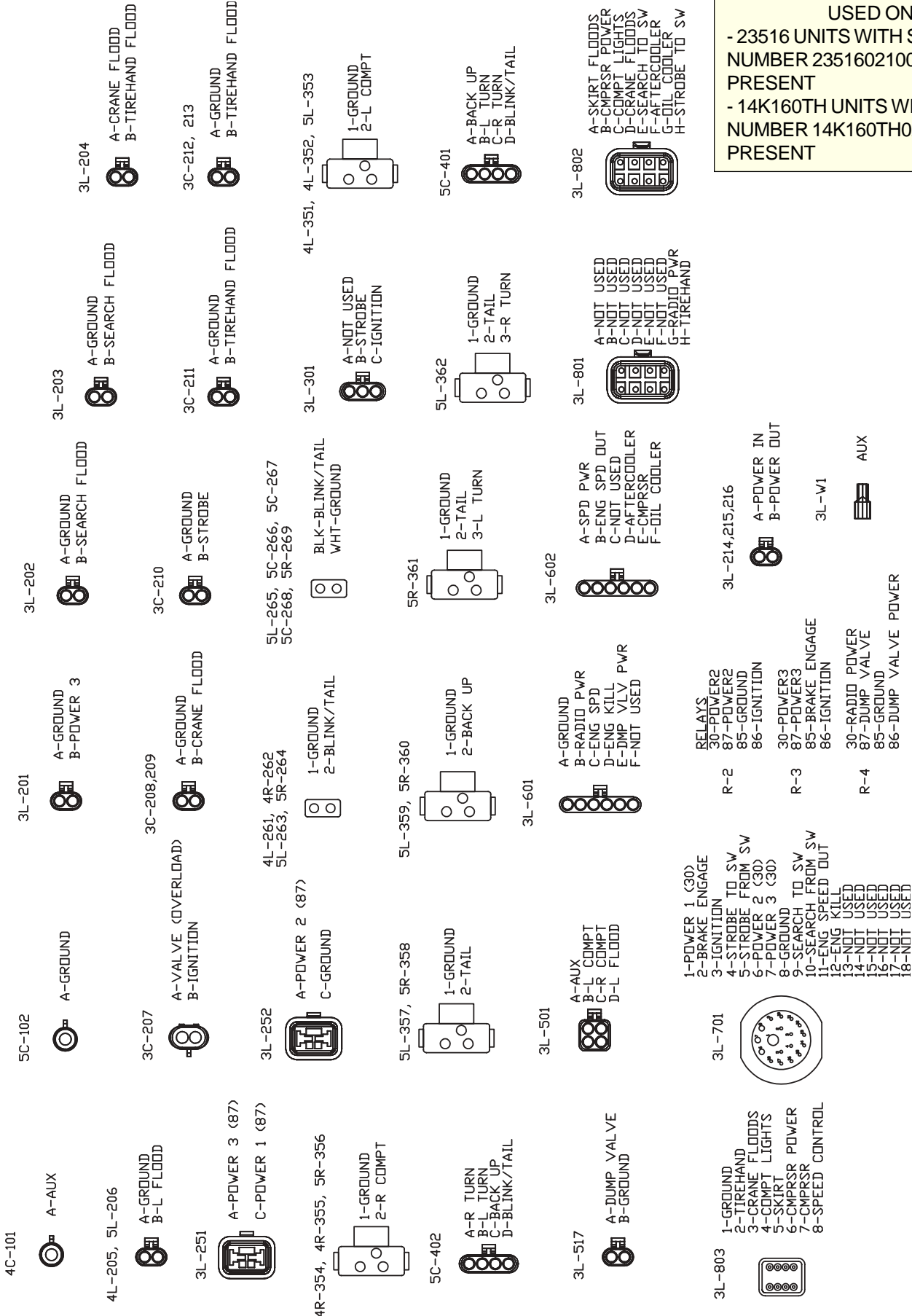

USED ON:
 - 23516 UNITS WITH SERIAL NUMBER 23516021001 TO PRESENT
 - 14K160TH UNITS WITH SERIAL NUMBER 14K160TH021003 TO PRESENT

ELECTRICAL CONTROL BOX (41718269-1)

1.	52715880	CABINET WELDMENT	1
2.	52713707	DOOR WELDMENT	1
3.	72661470	LATCHASM, 1-PT	1
4.	76393253	GASKET, LATCH W/STUDS	1
5.	77041486	SWITCH, E-STOP	1
6.	60121574	BRACKET, FUSE/RELAY BOX	1
7.	77040424	LIGHT, WORK LAMP	2
8.	72661383	HINGE, SS 10-GA	2
9.	89393637	WEATHERSTRIP, 1/2X1/2 TRIMLOC	5.5'
10.	77044468	CONNECTOR 1/2" STR REL .12-.25	1

11.	72601725	SCR-MACH 6-32 1/2 RDH PHLPS	2
12.	72601726	NUT 6-32 HEX NYLOC	2
13.	72060643	SCR-MACH 10-24 X 1.50 RDH SST	4
14.	72601652	SCR-MACH 1/4-20X3/4 TRHTORXSS	8
15.	72061004	SCR-SHT MET 14X3/4 SLT HEXZ	8
16.	72062194	NUT-SS 1/4-20 NYLOC	6
17.	72062264	NUT-1/4-20 WELD TP2120	2
18.	72062053	NUT 10-24 HEX ZINC	4
20.	72060835	SCR-SELF TAP 8-18 3/4 HHZINC	5
21.	72063166	WASHER SS 1/4 WRT 18-8 5/8 OD	4
22.	70396515	DECAL-WARNING, NO STORAGE ELEC. CABINET	1REF

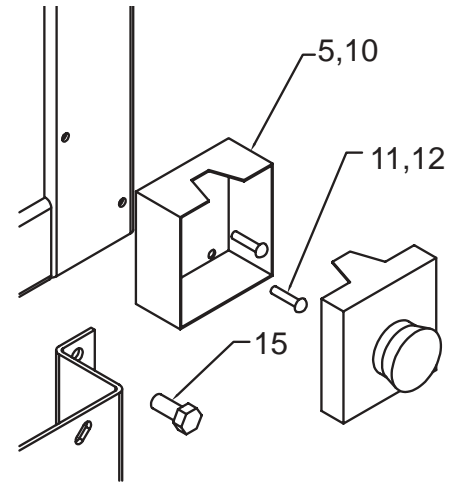
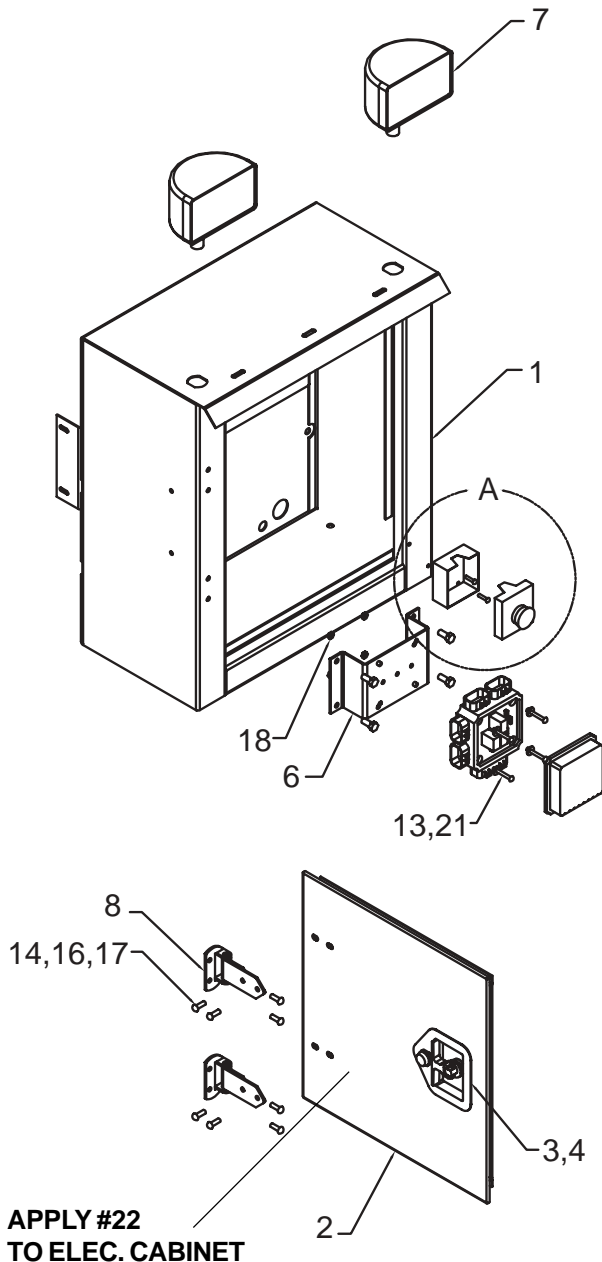

VIEW A

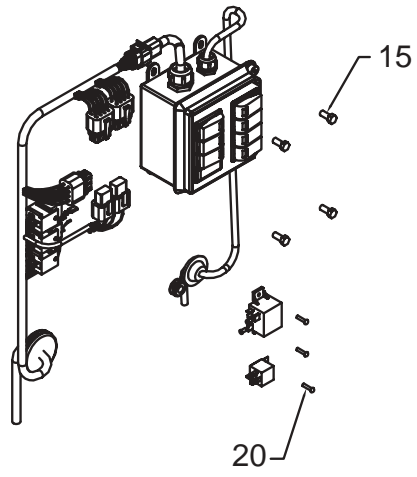

NOTES:

1. INSTALL WEATHERSTRIP (ITEM #9) AROUND DOOR OPENING.
2. INSTALL DUAL-LOCK FASTENER (ITEM #19) INSIDE LEFT SIDE WALL OF CABINET. USE ITEM #19 TO MOUNT RADIO REMOTE CONTROL CHARGER. (USE 2 STRIPS ON CABINET WALL AND 2 STRIPS ON CHARGER.)

ELEC CONTROL BOX ASM (41718269-2)

1.	77044919	HARNESS, SWITCH BOX OUT	1
2.	77441086	HARNESS, SWITCH BOX IN	1
3.	77441085	HARNESS, CRANE POWER	1
4.	77044935	FUSE/RELAY BOX	1
5.	77044797	SWITCH BOX	1
6.	77041504	SWITCH, ROCKER MTG PAN MID	4
7.	77041502	SWITCH, ROCKER MTG PAN END	4
8.	77041500	SWITCH, ROCKER BODY	7
9.	77041499	SWITCH, ROCKER RED ACT.	7
10.	77041571	SWITCH, ROCKER PLUG	1
11.	77041251	RELAY, 40 AMP	3
12.	77040391	RELAY, 12V DC 75 AMP	1
13.	77044573	CONNECT., PKRD M 2-WAY WP	1
14.	77044552	TERMINAL, MALE 18-20 GA WP	2
15.	70394069	SEAL, CABLE CONNECTOR	2
16.	70395669	DECAL, OTR LIGHT SWITCH	1
17.	76391200	RUBBER GROMMET, 9/16	1

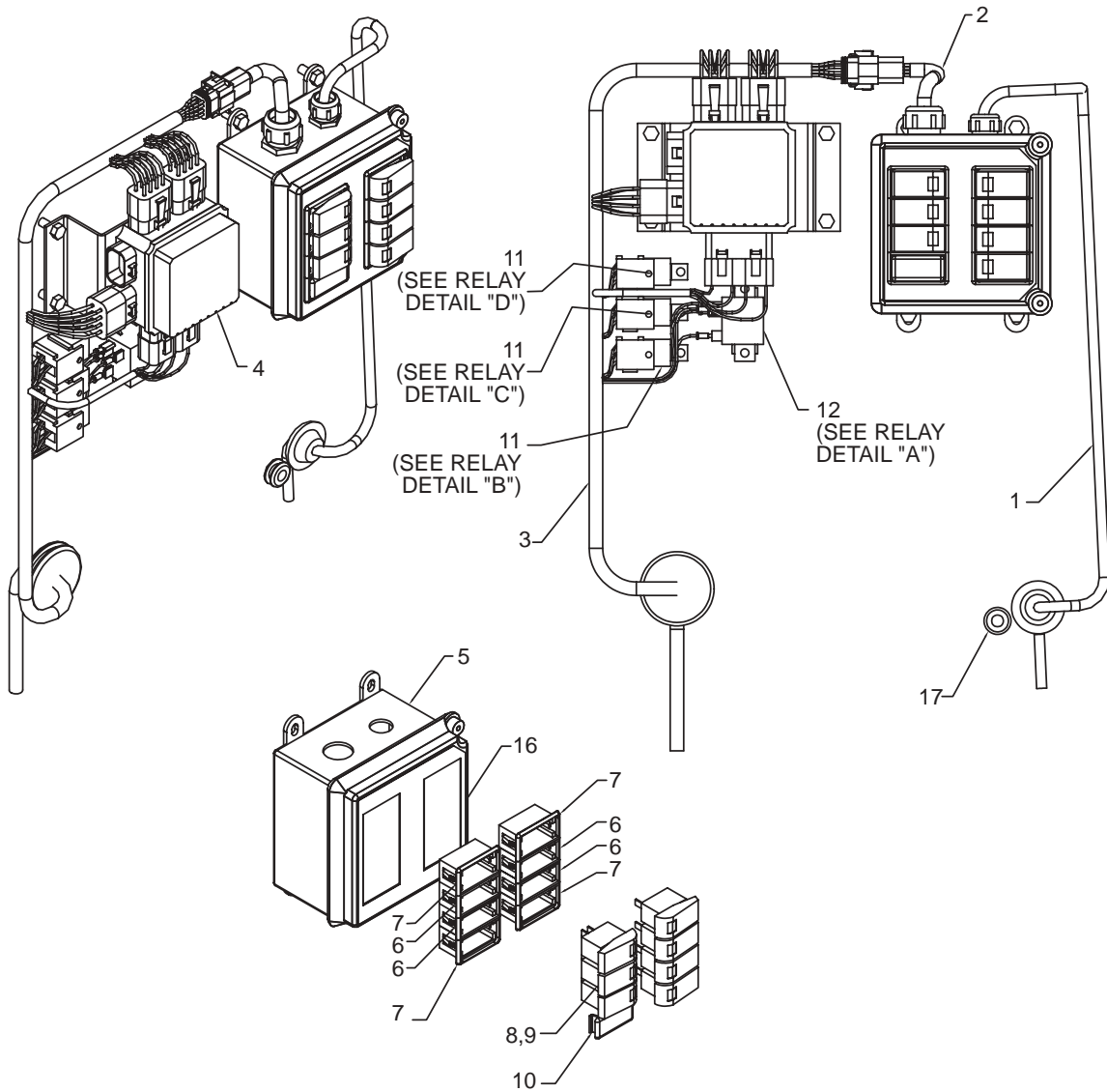

NOTES:
 1. FOR COMPLETE WIRING CONNECTIONS, SEE COMMANDER IV WIRING SCHEMATIC

ELEC CONTROL BOX (41718269-3)

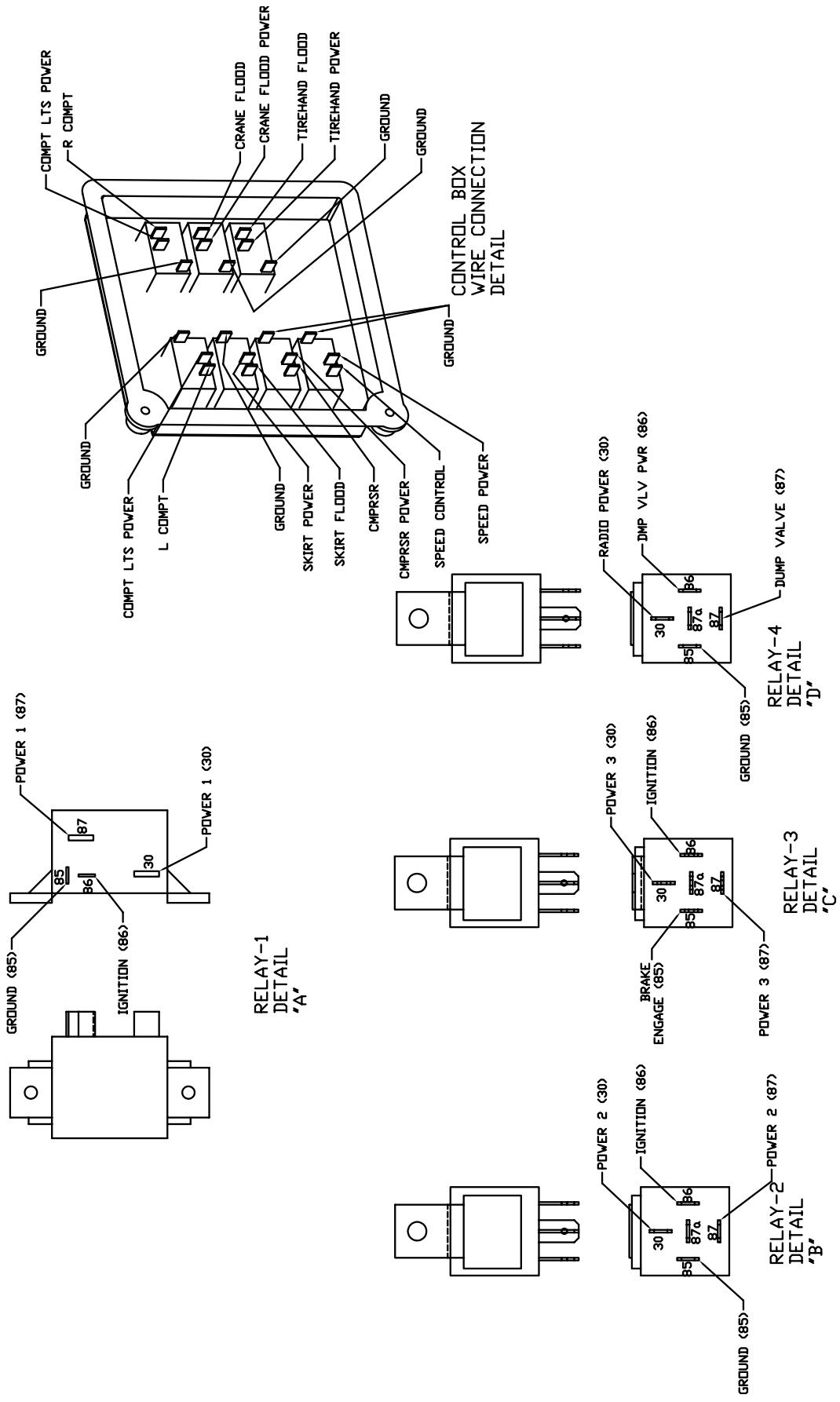

CHASSIS WIRING- COMMANDER IV (99903160)

- 1. 77041616 FUSE-MAXI 40 AMP (WAS 77044672) 2
- 2. 77041678 FUSE BLOCK- 4 POSITION 1
(WAS 77040060)
- 3. 72060835 SCREW-SELF-TAP #8-18 X 3/4 HHZ 4
(WAS 72061099)
- 4. 77041619 FUSE-MAXI 60 AMP 1
- 5. 60251088 BRKT-RELAY & MAXI FUSE BLK 1
(WAS 77041628)
- 6. 77441110 CABLE POWER RED #6X16 1
(WAS 77040049)
- 7. 77041606 FUSE AGC 7.5 1
- 8. 77044691 FUSE HOLDER 1
- 9. 77040048 TERM-BUTT CONN 6
- 10. 51717388 KIT-EFM 1
- 11. 70145421 HEAT SHRINK (NOT SHOWN) 12"
(WAS 60250624)
- 12. 77044915 HARNESS 1
- 13. 72061739 SCR-TEK 12-14 X 1.00 HWH (N/S) 2
(RMV 77041615)

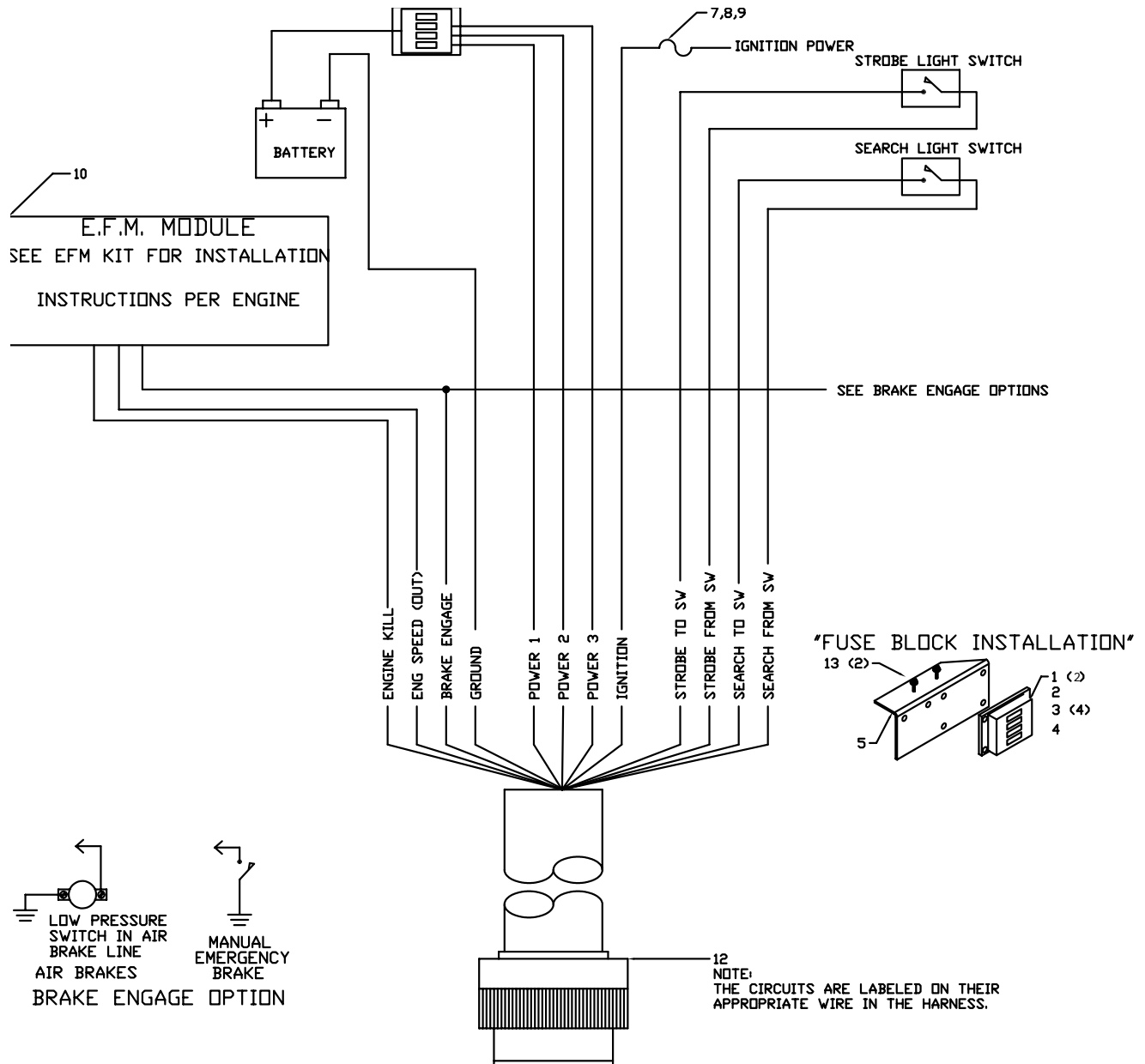

USED ON 23516 UNITS WITH SERIAL NUMBER
23516021001 TO PRESENT

HYDRAULIC SHUTDOWN KIT (99903465)

- | | | | |
|-----|----------|---|------|
| 1. | 51396300 | HOSE-FF .75X 36.00 OAL(12-12) | 1REF |
| 2. | 52719517 | COVER WLDMT-14K160TH
(WAS 60124754) | 1 |
| 3. | 52713782 | HANDLE-HYD SHUTDOWN | 2 |
| 4. | 60120092 | TUBE-RD .75IDX 1.00ODX 15.50 | 1 |
| 5. | 73055278 | VALVE ASM-REL/SOL HYD SHUTD | 1 |
| 6. | 77041459 | SWITCH-LIMIT | 1 |
| 7. | 72533000 | TEE-SWVL NUT RUN JIC 16 | 1 |
| 8. | 72053767 | ELBOW-M STR/90/M JIC 12 12 | 2 |
| 9. | 72532366 | ADPTR-M STR/M JIC 12 12 | 1 |
| 10. | 77044468 | CONNECTOR- .50 STR RLF .12-.25 | 1 |
| 11. | 72060057 | CAP SCR .38-16X 4.50 HH GR5 Z | 2 |
| 12. | 72062103 | NUT .38-16 HEX NYLOC ZINC | 7 |
| 13. | 72060004 | CAP SCR .25-20X 1.00 HH GR5 Z | 4 |
| 14. | 72062104 | NUT .25-20 HEX NYLOC ZINC | 4 |
| 15. | 72063215 | WASHER-BELLVILLE .38 SS | 2 |
| 16. | 72063003 | WASHER .38 W FLAT ANSI B27.2Z | 2 |
| 17. | 72062002 | NUT .38-16 HEX ZINC | 10 |
| 18. | 72060052 | CAP SCR .38-16X 2.50 HH GR5 Z | 3 |
| 19. | 70146062 | KNOB-CNTRL HANDLE | 7 |
| 20. | 60124863 | HANDLE-GRESEN V20 VB 5.00 LG | 1 |
| 21. | 60124864 | HANDLE-GRESEN V20 VB 6.00 LG | 6 |
| 22. | 72532971 | ELBOW-M JIC/F JIC SW 16 16 | 1 |
| 23. | 72060051 | CAP SCR .38-16X 2.25 HH GR5 Z | 2 |
| 24. | 72063001 | WASHER .25 W FLAT ANSI B27.2Z | 4 |
| 25. | 51396303 | HOSE-FJ .75X 61.00 OAL(16-12) | 1REF |
| 26. | 72053508 | ZERK-NPT .12 (PART OF HYD KIT) | 1REF |
| 27. | 72053638 | ADPTR-MPT/FPT SWVL .12 .12
(PART OF HYD KIT) | 1REF |
| 28. | 53000718 | GREASE EXT-55.00 OAL 53.00HOSE
(PART OF HYD KIT) | 1REF |

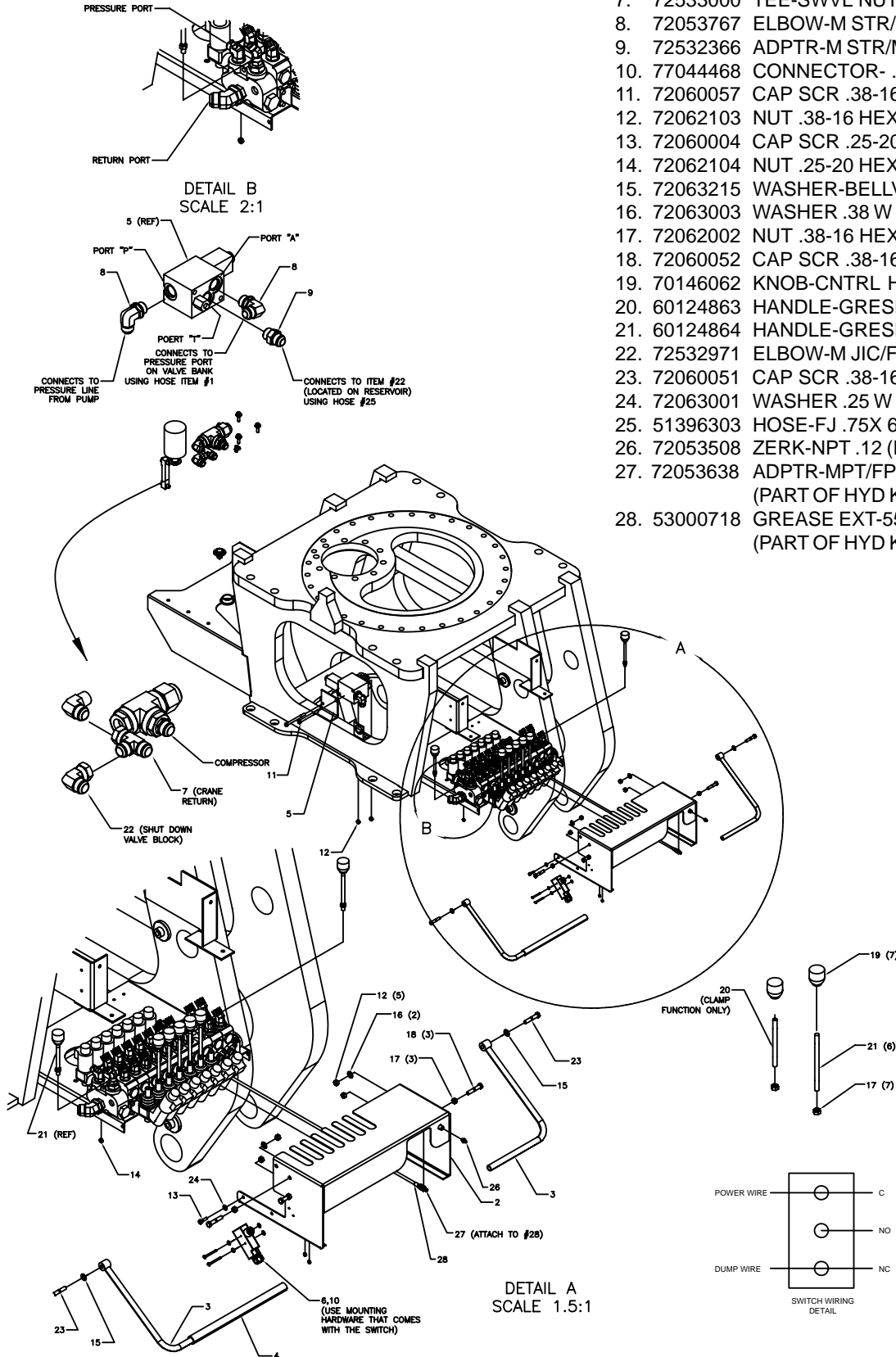

DETAIL A
SCALE 1.5:1

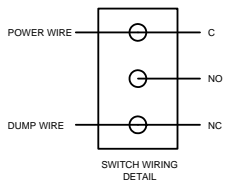

USED ON 23516 UNITS PRIOR TO SERIAL NUMBER 23516021001.

23516 SHUTDOWN CONVERSION KIT (99903466)

1.	51396300	HOSE FF 3/4X36.00 OAL	1
2.	60124754	COVER-SHUT DOWN V/B	1
3.	52713782	HANDLE-HYD SHUTDOWN	2
4.	60120092	TUBE-RD 3/4ID X 1.0 OD X 15.50	1
5.	73055278	VALVE ASM-RELIEF/SOL	1
6.	77041459	LIMIT SWITCH ZE-N-2 S	1
7.	72533000	TEE-SWIVEL NUT RUN JIC 16	1
8.	72053767	ELBOW #12 MSTR #12 MJIC 90°	2
9.	72532366	ADPTR-#12MSTR #12MJIC	1
10.	77044468	CONNECTOR 1/2 STR RLF 1/8-1/4	1
11.	72060057	CAP SCR 3/8-16 X 4.5 HHGR5Z	2
12.	72062103	NUT 3/8-16 HEX NYLOC	7
13.	72060004	CAP SCR 1/4-20 X 1.00 HHGR5Z	4
14.	72062104	NUT 1/4-20 HEX NYLOC ZINC	4
15.	72063215	WASHER BELLVILLE 3/8 SS	2
16.	72063003	WASHER 3/8 FLAT	2
17.	72062002	NUT 3/8-16 HEX ZINC	10
18.	72060052	CAP SCR 3/8-16 X2.50 HHGR5Z	3
19.	70146062	KNOB-CTRL HANDLE (GRES 8815)	7
20.	60124863	HANDLE 5" LONG	1
21.	60124864	HANDLE 6" LONG	6
22.	72532971	ELBOW #16MJIC #16FJIC SW	1
23.	72060051	CAP SCR 3/8-16 X 2.25 HHGR5Z	2
24.	72063001	WASHER 1/4 FLAT	4
25.	51396303	HOSE-FJ 3/4 X 61.00 OAL	1
26.	70396301	DECAL-CONTROL 23516	1
27.	60124853	BRACKET-SHUTDOWN VB	1

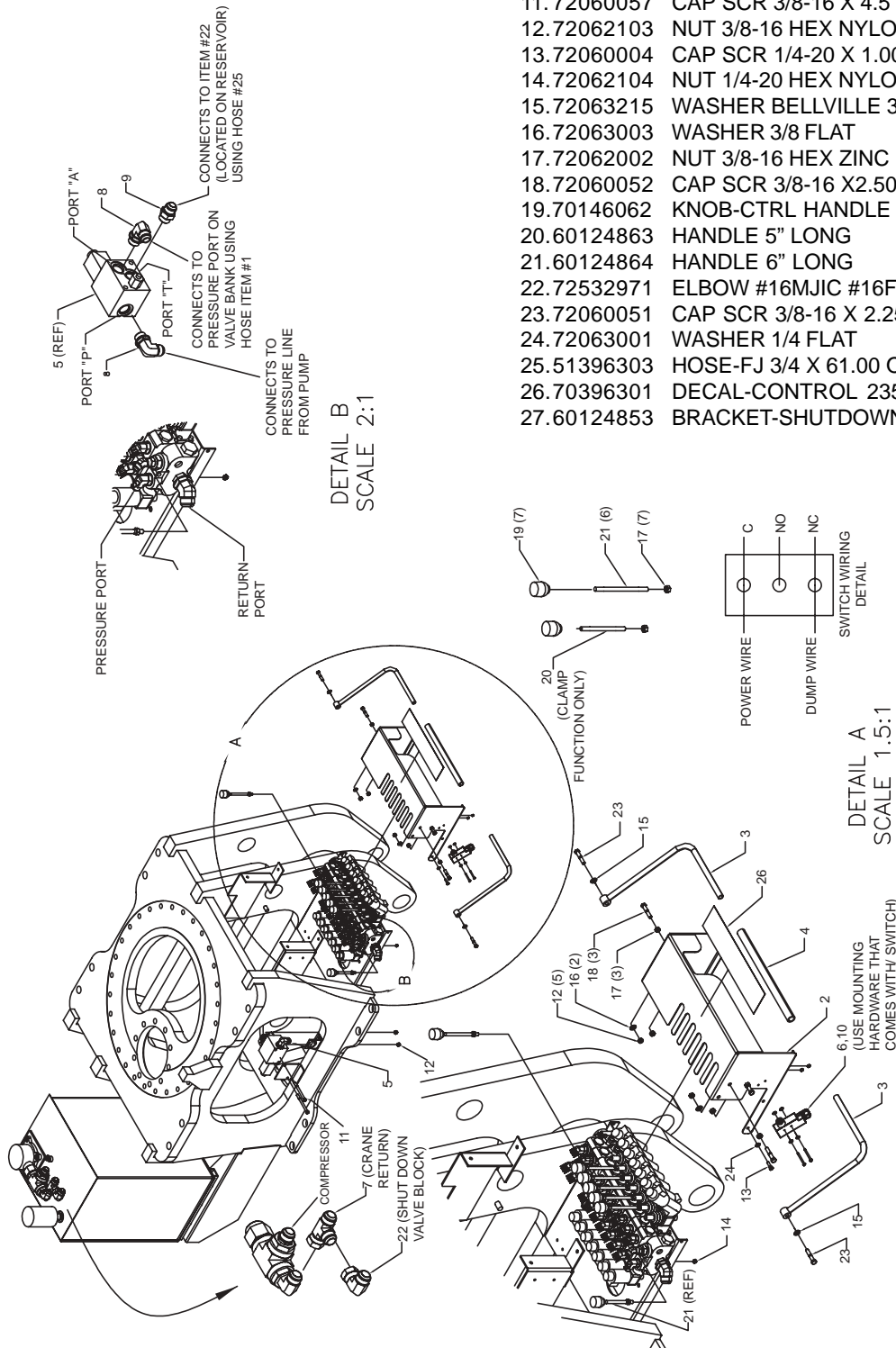

GEAR REDUCER (71570570)

8. 76039295	MOTOR GASKET	1
20. 70142375	DRIVE SCREW	2
33. 70055017	CONE BEARING M802048	2
34. 70055020	CUP BEARING M802011	2
41. 76394070	SEAL, NATURAL	1
42. 76396302	SEAL CR #26110	1
59. 72533439	PLUG, ALEMITE	1
60. 70143428	LABEL PLATE	1
64. 72061133	CAP SCREW, FERRY 7/16 NC X1	12

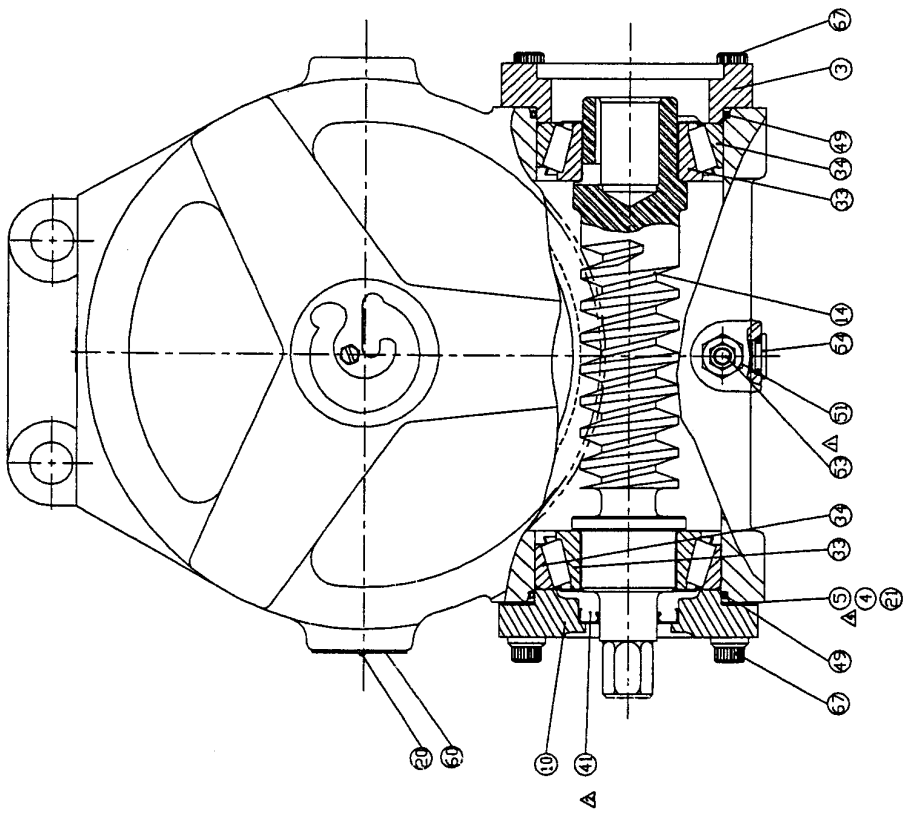
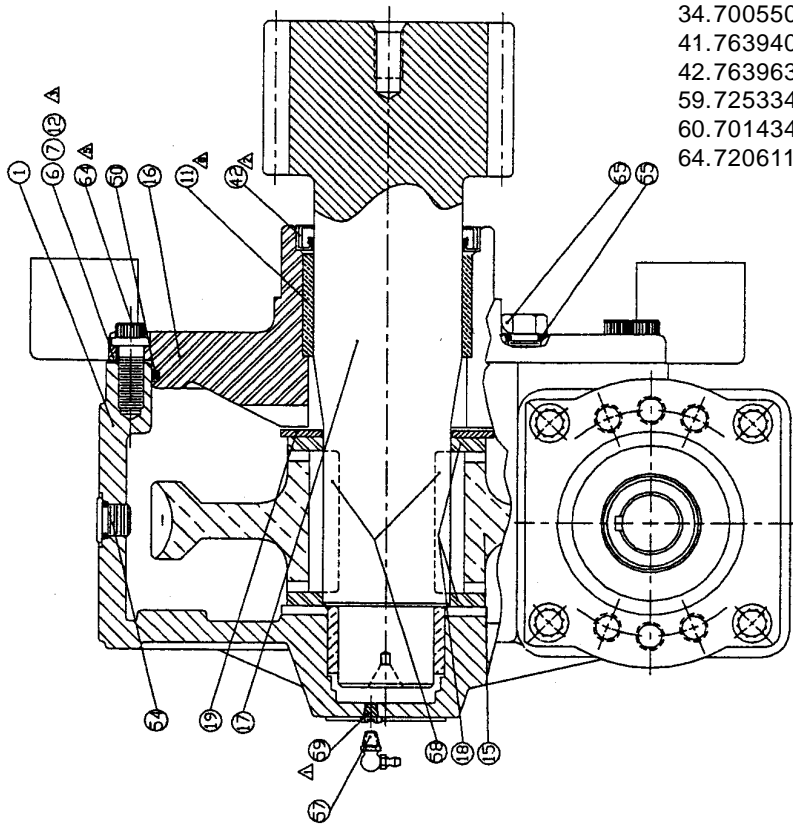

SECTION 4. GENERAL REFERENCE

INSPECTION CHECKLIST	3
WIRE ROPE INSPECTION	7
HOOK INSPECTION	7
HOLDING VALVE INSPECTION	8
ANTI-TWO BLOCKING DEVICE INSPECTION	8
TORQUE DATA CHART - DOMESTIC	9
TORQUE DATA CHART - METRIC	10
TURNTABLE BEARING FASTENER TIGHTENING SEQUENCE	11
TURNTABLE BEARING INSPECTION FOR REPLACEMENT	12

NOTICE	
The user of this form is responsible in determining that these inspections satisfy all applicable regulatory requirements	
OWNER/COMPANY	
CONTACT PERSON	
CRANE MAKE & MODEL	
CRANE SERIAL NUMBER	
UNIT I.D. NUMBER	
LOCATION OF UNIT	

<i>Inspection Checklist</i>	
CRANES	
TYPE OF INSPECTION (check one) <input type="checkbox"/> DAILY (if deficiency found) <input type="checkbox"/> QUARTERLY <input type="checkbox"/> MONTHLY <input type="checkbox"/> ANNUAL	
DATE INSPECTED	
HOUR METER READING (if applicable)	
INSPECTED BY (print)	
SIGNATURE OF INSPECTOR	

REV. 6-18-99

1

TYPE OF INSPECTION
NOTES:
Daily and monthly inspections are to be performed by a “designated” person, who has been selected or assigned by the employer or the employer’s representative as being competent to perform specific duties.

Quarterly and annual inspections are to be performed by a “qualified” person who, by possession of a recognized degree in an applicable field or certificate of professional standing, or who, by extensive knowledge, training and experience has successfully demonstrated the ability to solve or resolve problems related to the subject matter and work.

One hour of normal crane operation assumes 20 complete cycles per hour. If operation exceeds 20 cycles per hour, inspection frequency should be increased accordingly.

Consult Operator / Service Manual for additional inspection items, service bulletins and other information.

Before inspecting and operating crane, crane must be set up away from power lines and leveled with outriggers fully extended.

DAILY (D): Before each day of operation, those items designated with a **(D)** must be inspected. This inspection need not be recorded unless a deficiency (**X**) is found. If the end user chooses to record all daily inspections and those daily inspections include the monthly inspection requirements, there would be no need for a separate monthly inspection.

MONTHLY (M): Monthly inspections or 100 hours of normal operation (which ever comes first) includes all daily inspections plus items designated with an **(M)**. This inspection must be recorded.

QUARTERLY (Q): Every three to four months or 300 hours of normal operation (which ever comes first) includes all daily and monthly inspection items plus items designated with a **(Q)**. This inspection must be recorded.

ANNUAL (A): Each year or 1200 hours of normal operation (which ever comes first) includes all items on this form which encompasses daily, monthly and quarterly inspections plus those items designated by **(A)**. This inspection must be recorded.

FREQUENCY	ITEM	KEY	<input checked="" type="checkbox"/> = SATISFACTORY <input checked="" type="checkbox"/> = DEFICIENCY (must be corrected prior to operation)	R = RECOMMENDATION (should be considered for corrective action) NA = NOT APPLICABLE	STATUS <input checked="" type="checkbox"/> X R, NA
			INSPECTION DESCRIPTION		
D	1	Labels	All load charts, safety & warning labels, & control labels are present and legible.		
D	2		Check all safety devices for proper operation.		
D	3	Controls	Control mechanisms for proper operation of all functions, leaks & cracks.		
D	4	Station	Control and operator’s station for dirt, contamination by lubricants, & foreign materials.		
D	5	Hyd System	Hydraulic system (hoses, tubes & fittings) for leakage & proper oil level.		
D	6	Hook	Presence & proper operation of hook safety latches.		
D	7	Rope	Proper reeving of wire rope on sheaves & winch drum.		
D	8	Pins	Proper engagement of all connecting pins & pin retaining devices.		
D	9	General	Overall observation of crane for damaged or missing parts, cracked welds & presence of safety covers.		
D	10	Operation	During operation, observe crane for abnormal performance, unusual wear (loose pins, wire rope damage, etc.). If observed, discontinue use & determine cause & severity of hazard.		
D	11	Remote Ctrls	Operate remote control devices to check for proper operation.		
D	12	Electrical	Operate all lights, alarms, etc. to check for proper operation.		
D	13	Anti 2-Blocking	Operate anti 2-blocking device to check for proper operation.		
D	14		Other		
D	15		Other		

<h1 style="margin: 0;">Inspection Checklist</h1>	<h1 style="margin: 0;">CRANES</h1>	<h1 style="margin: 0;">2</h1>
--	------------------------------------	-------------------------------

FREQUENCY	ITEM	KEY	✓ = SATISFACTORY ✗ = DEFICIENCY (must be corrected prior to operation)	R = RECOMMENDATION (should be considered for corrective action) NA = NOT APPLICABLE	STATUS
			INSPECTION DESCRIPTION	✓, ✗, R, NA	
M	16	Daily	All daily inspection items.		
M	17	Cylinders	Visual inspection of cylinders for leakage at rod, fittings & welds. Damage to rod & case.		
M	18	Valves	Holding valves for proper operation.		
M	19	Valves	Control valve for leaks at fittings & between sections.		
M	20	Valves	Control valve linkages for wear, smoothness of operation & tightness of fasteners.		
M	21	General	Bent, broken or significantly rusted/corroded parts.		
M	22	Electrical	Electrical systems for presence of dirt, moisture & frayed wires.		
M	23	Structure	All structural members for damage.		
M	24	Welds	All welds for breaks & cracks.		
M	25	Pins	All pins for proper installation & condition.		
M	26	Hardware	All bolts, fasteners & retaining rings for tightness, wear & corrosion		
M	27	Wear Pads	Presence of wear pads.		
M	28	Pump & Motor	Hydraulic pumps & motors for leakage at fittings, seals & between sections.		
M	29	PTO	Transmission/PTO for leakage, abnormal vibration & noise.		
M	30	Hyd Fluid	Quality of hydraulic fluid and for presence of water.		
M	31	Hyd Lines	Hoses & tubes for leakage, abrasion damage, blistering, cracking, deterioration, fitting leakage & secured properly.		
M	32	Hook	Load hook for abnormal throat distance, twist, wear & cracks.		
M	33	Rope	Condition of load line.		
M	34	Manual	Presence of operator's manuals with unit.		
M	35		Other		
Q	36	Daily	All daily inspection items.		
Q	37	Monthly	All monthly inspection items.		
Q	38		Condition of wear pads		
Q	39	Rotation Sys	Rotation bearing for proper torque of all accessible mounting bolts.		
Q	40	Hardware	Base mounting bolts for proper torque.		
Q	41	Structure	All structural members for deformation, cracks & corrosion.		
	42		● Base		
	43		● Outrigger beams & legs		
	44		● Mast		
	45		● Inner boom		
	46		● Outer boom		
	47		● Extension(s)		
	48		● Jib boom		
	49		● Jib extension(s)		
	50		● Other		
Q	51	Hardware	Pins, bearings, shafts, gears, rollers, & locking devices for wear, cracks, corrosion & distortion.		
	52		● Rotation bearing(s)		
	53		● Inner boom pivot pin(s) & retainer(s)		
	54		● Outer boom pivot pin(s) & retainer(s)		
	55		● Inner boom cylinder pin(s) & retainer(s)		
	56		● Outer boom cylinder pin(s) & retainer(s)		
	57		● Extension cylinder pin(s) & retainer(s)		
	58		● Jib boom pin(s) & retainer(s)		
	59		● Jib cylinder pin(s) & retainer(s)		
	60		● Jib extension cylinder pin(s) & retainer(s)		
	61		● Boom tip attachments		
	62		● Other		
Q	63	Hyd Lines	Hoses, fittings & tubing for proper routing, leakage, blistering, deformation & excessive abrasion.		
	64		● Pressure line(s) from pump to control valve		
	65		● Return line(s) from control valve to reservoir		
	66		● Suction line(s) from reservoir to pump		
	67		● Pressure line(s) from control valve to each function		
	68		● Load holding valve pipe(s) and hose(s)		
	69		● Other		

WIRE ROPE INSPECTION

Wire rope with any of the deficiencies shown below shall be removed and replaced immediately.

- A. Corrosion can be cause for replacement. Any development of corrosion must be noted and monitored closely.
- B. When there are either 3 broken wires in one strand or a total of six broken wires in all strands in any one rope lay.

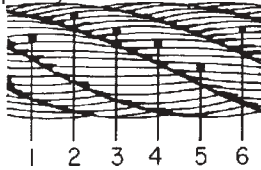

- C. When flat spots on the outer wires appear and those outside wires are less than 2/3 the thickness of the unworn outer wire.

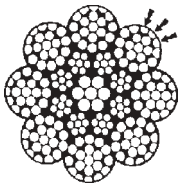

- D. When there is a decrease of diameter indicating a core failure.

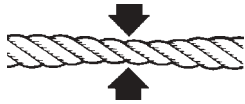

- E. When kinking, crushing, birdcaging or other distortion occurs.

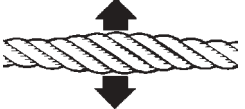

- F. When there is noticeable heat damage (discoloration) of the rope by any means.



- G. When the diameter is reduced from nominal size by 1/32" or more.



- H. If a broken wire protrudes or loops out from the core of the rope.



HOOK INSPECTION

Hooks having any of the listed deficiencies shall be removed from service unless a qualified person approves their continued use and initiates corrective action. Hooks approved for continued use shall be subjected to periodic inspection.

A. DISTORTION

Bending / Twisting

A bend or twist exceeding 10° from the plane of the unbent hook.

Increased Throat Opening

HOOK WITHOUT LATCH: An increase in throat opening exceeding 15% (Or as recommended by the manufacturer)

HOOK WITH LATCH: An increase of the dimension between a fully-opened latch and the tip section of the hook exceeding 8% (Or as recommended by the manufacturer)

B. WEAR

If wear exceeds 10% of the original sectional dimension. (Or as recommended by the manufacturer)

C. CRACKS, NICKS, GOUGES

Repair of cracks, nicks, and gouges shall be carried out by a designated person by grinding longitudinally, following the contour of the hook, provided that no dimension is reduced more than 10% of its original value. (Or as recommended by the manufacturer) (A qualified person may authorize continued use if the reduced area is not critical.)

D. LATCH

Engagement, Damage & Malfunction

If a latch becomes inoperative because of wear or deformation, and is required for the service involved, it shall be replaced or repaired before the hook is put back into service. If the latch fails to fully close the throat opening, the hook shall be removed from service or "moused" until repairs are made.

E. HOOK ATTACHMENTS & SECURING MEANS

If any indication of distortion, wear, cracks, nicks or gouges are present, unless a qualified person authorizes their use. (Or as recommended by the manufacturer)

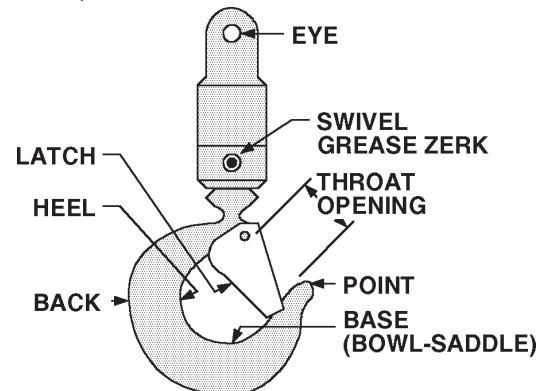

HOLDING VALVE INSPECTION

The cylinders are equipped with holding valves that prevent sudden movement of the cylinder rods in the event of a hydraulic hose or other hydraulic component failure. The valve is checked in the following manner:

1. With a full rated load, extend the cylinder in question and kill the engine.
2. Operate the control valve to retract the cylinder. If the cylinder "creeps", replace the holding valve. If the cylinder does not "creep", the valve is serviceable.

ANTI-TWO BLOCKING DEVICE INSPECTION

(See Vol. 1, Operation, Maintenance and Repair for a complete description)

The anti two block system should be checked daily as follows:

1. Examine flexible rod and weight to insure free unrestricted mechanical operation
2. Examine cord for damage, cuts or breaks. Grasp cord and pull to check operation of cord reel. The cord should retract on reel when released.
3. Start vehicle, engage PTO and slowly winch loadline up until anti-two block weight comes in contact with the hook end of the loadline cable. At the moment the weight is fully supported, a marked difference in winch operation should be noted. At this point, the winch up function should become very sluggish or non-functioning and have very little pull capability. Slowly increase truck engine speed while simultaneously actuating the winch up function. The winch characteristics should remain sluggish with little or no tensioning of the cable. If operation other than as described occurs, stop immediately and investigate. Failure to do so will risk damage to the cable or the crane. If all is well at this point, actuate the boom extend function slowly, and gradually increase to full actuation. Once again the function should be sluggish or non-existent with no tightening of the winch cable. If operation other than described occurs, stop immediately and reverse the function.

The final check involves actuating both the winch up and extend functions together and checking for proper operation of the anti two blocking circuit. Once again, start slowly and stop if it appears the cable is being tensioned.

If the anti two block function appears to be functioning normally, winch the cable down until the sensing weight swings free.

COARSE THREAD BOLTS

SIZE (DIA-TPI)	BOLT DIA (INCHES)	TIGHTENING TORQUE			
		SAE J429 GRADE 5		SAE J429 GRADE 8	
		PLAIN (FT-LBS)	PLATED (FT-LBS)	PLAIN (FT-LBS)	PLATED (FT-LBS)
5/16-18	0.3125	17	13	25	18
3/8-16	0.3750	31	23	44	33
7/16-14	0.4375	49	37	70	52
1/2-13	0.5000	75	57	105	80
9/16-12	0.5625	110	82	155	115
5/8-11	0.6250	150	115	220	160
3/4-10	0.7500	265	200	375	280
7/8-9	0.8750	395	295	605	455
1-8	1.0000	590	445	910	680
1 1/8-7	1.1250	795	595	1290	965
1 1/4-7	1.2500	1120	840	1815	1360
1 3/8-6	1.3750	1470	1100	2380	1780
1 1/2-6	1.5000	1950	1460	3160	2370

When using the torque data in the charts above, the following rules should be observed.



1. Bolt manufacturer's particular specifications should be consulted when provided.
2. Flat washers of equal strength must be used.
3. All torque measurements are given in foot-pounds. To convert to inch-pounds, multiply by 12.
4. Torque values specified are for bolts with residual oils or no special lubricants applied. If special lubricants of high stress ability, such as Never-Seez compound graphite and oil, molybdenum disulphite, colloidal copper or white lead are applied, multiply the torque values in the charts by the factor .90. The use of Loctite does not affect the torque values listed above.

WARNING

Anytime a gear-bearing bolt is removed, it must be replaced with a new bolt of the identical grade and size. Once a bolt has been torqued to 75% of its proof load and then removed, the torque coefficient may no longer be the same as when the bolt was new thus giving indeterminate clamp loads after torquing. Failure to replace gear-bearing bolts may result in bolt failure due to metal fatigue causing serious injury or DEATH.

TORQUE DATA CHART - DOMESTIC

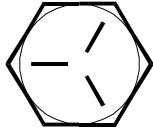
FINE THREAD BOLTS

SIZE (DIA-TPI)	BOLT DIA (INCHES)	TIGHTENING TORQUE			
		 SAE J429 GRADE 5		 SAE J429 GRADE 8	
		PLAIN (FT-LBS)	PLATED (FT-LBS)	PLAIN (FT-LBS)	PLATED (FT-LBS)
5/16-24	0.3125	19	14	27	20
3/8-24	0.3750	35	26	49	35
7/16-20	0.4375	55	41	78	58
1/2-20	0.5000	90	64	120	90
9/16-18	0.5625	120	90	170	130
5/8-18	0.6250	170	130	240	180
3/4-16	0.7500	300	225	420	315
7/8-11	0.8750	445	325	670	500
1-12	1.0000	645	485	995	745
1 1/8-12	1.1250	890	670	1445	1085
1 1/4-12	1.2500	1240	930	2010	1510
1 3/8-12	1.3750	1675	1255	2710	2035
1 1/2-12	1.5000	2195	1645	3560	2670

COARSE THREAD BOLTS

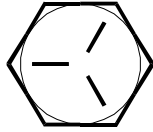
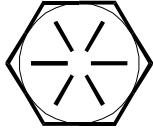
SIZE (DIA-TPI)	BOLT DIA (INCHES)	TIGHTENING TORQUE			
		 SAE J429 GRADE 5		 SAE J429 GRADE 8	
		PLAIN (FT-LBS)	PLATED (FT-LBS)	PLAIN (FT-LBS)	PLATED (FT-LBS)
5/16-18	0.3125	17	13	25	18
3/8-16	0.3750	31	23	44	33
7/16-14	0.4375	49	37	70	52
1/2-13	0.5000	75	57	105	80
9/16-12	0.5625	110	82	155	115
5/8-11	0.6250	150	115	220	160
3/4-10	0.7500	265	200	375	280
7/8-9	0.8750	395	295	605	455
1-8	1.0000	590	445	910	680
1 1/8-7	1.1250	795	595	1290	965
1 1/4-7	1.2500	1120	840	1815	1360
1 3/8-6	1.3750	1470	1100	2380	1780
1 1/2-6	1.5000	1950	1460	3160	2370

When using the torque data in the charts above, the following rules should be observed.



1. Bolt manufacturer's particular specifications should be consulted when provided.
2. Flat washers of equal strength must be used.
3. All torque measurements are given in foot-pounds. To convert to inch-pounds, multiply by 12.
4. Torque values specified are for bolts with residual oils or no special lubricants applied.
If special lubricants of high stress ability, such as Never-Seez compound graphite and oil, molybdenum disulphite, colloidal copper or white lead are applied, multiply the torque values in the charts by the factor .90. The use of Loctite does not affect the torque values listed above.

WARNING

Anytime a gear-bearing bolt is removed, it must be replaced with a new bolt of the identical grade and size. Once a bolt has been torqued to 75% of its proof load and then removed, the torque coefficient may no longer be the same as when the bolt was new thus giving indeterminate clamp loads after torquing. Failure to replace gear-bearing bolts may result in bolt failure due to metal fatigue causing serious injury or DEATH.

TORQUE DATA CHART - METRIC

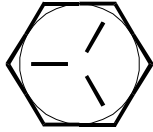
FINE THREAD BOLTS

SIZE (DIA-TPI)	BOLT DIA (INCHES)	TIGHTENING TORQUE			
		 SAE J429 GRADE 5		 SAE J429 GRADE 8	
		PLAIN (KG-M)	PLATED (KG-M)	PLAIN (KG-M)	PLATED (KG-M)
5/16-24	0.3125	3	2	4	3
3/8-24	0.3750	5	4	7	5
7/16-20	0.4375	8	6	11	8
1/2-20	0.5000	12	9	17	12
9/16-18	0.5625	17	12	24	18
5/8-18	0.6250	24	18	33	25
3/4-16	0.7500	41	31	58	44
7/8-11	0.8750	62	45	93	69
1-12	1.0000	89	67	138	103
1 1/8-12	1.1250	123	93	200	150
1 1/4-12	1.2500	171	129	278	209
1 3/8-12	1.3750	232	174	375	281
1 1/2-12	1.5000	304	228	492	369

COARSE THREAD BOLTS

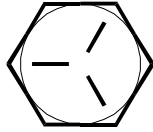
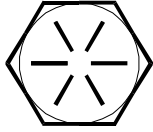
SIZE (DIA-TPI)	BOLT DIA (INCHES)	TIGHTENING TORQUE			
		 SAE J429 GRADE 5		 SAE J429 GRADE 8	
		PLAIN (KG-M)	PLATED (KG-M)	PLAIN (KG-M)	PLATED (KG-M)
5/16-18	0.3125	2	2	3	2
3/8-16	0.3750	4	3	6	5
7/16-14	0.4375	7	5	10	7
1/2-13	0.5000	10	8	15	11
9/16-12	0.5625	15	11	21	16
5/8-11	0.6250	21	16	30	22
3/4-10	0.7500	37	28	52	39
7/8-9	0.8750	55	41	84	63
1-8	1.0000	82	62	126	94
1 1/8-7	1.1250	110	82	178	133
1 1/4-7	1.2500	155	116	251	188
1 3/8-6	1.3750	203	152	329	246
1 1/2-6	1.5000	270	210	438	328

When using the torque data in the charts above, the following rules should be observed.

1. Bolt manufacturer's particular specifications should be consulted when provided.
2. Flat washers of equal strength must be used.
3. All torque measurements are given in kilogram-meters.
4. Torque values specified are for bolts with residual oils or no special lubricants applied.
If special lubricants of high stress ability, such as Never-Seez compound graphite and oil, molybdenum disulphite, colloidal copper or white lead are applied, multiply the torque values in the charts by the factor .90. The use of Loctite does not affect the torque values listed above.

WARNING

Anytime a gear-bearing bolt is removed, it must be replaced with a new bolt of the identical grade and size. Once a bolt has been torqued to 75% of its proof load and then removed, the torque coefficient may no longer be the same as when the bolt was new thus giving indeterminate clamp loads after torquing. Failure to replace gear-bearing bolts may result in bolt failure due to metal fatigue causing serious injury or DEATH.

TURNTABLE BEARING INSPECTION FOR REPLACEMENT

Before a bearing is removed from a crane for inspection, one of the following conditions should be evident:

1. Metal particles present in the bearing lubricant.
2. Increased drive power required to rotate the crane.
3. Noise emitting from the bearing during crane rotation.
4. Rough crane rotation.
5. Uneven or excessive wear between the pinion gear and turntable gear.

If none of the above conditions exists, the bearing is functioning properly and need not be replaced. But, if one or more of the above conditions exists, inspection may be required. Limits are measured in "TILT" which is dependent on the internal clearances of the bearing. TILT is the most practical determination of a bearings internal clearance once mounted on a crane.

Periodic readings indicating a steady increase in TILT may be an indicator of bearing wear. Note that a bearing found to have no raceway cracks or other structural irregularities should be reassembled and returned to service.

TEST PROCEDURE

STEP 1.

With the crane horizontal and fully extended, measure between the top and bottom mounting surfaces of the turntable bearing (A1), using a dial indicator for accuracy.

STEP 2.

Reverse the load by applying minimal downward pressure on the boom while the boom is in the boom support or on a solid surface. Again measure A2.

STEP 3.

Subtract A1 from A2 to determine tilt and compare the result with the accompanying chart.

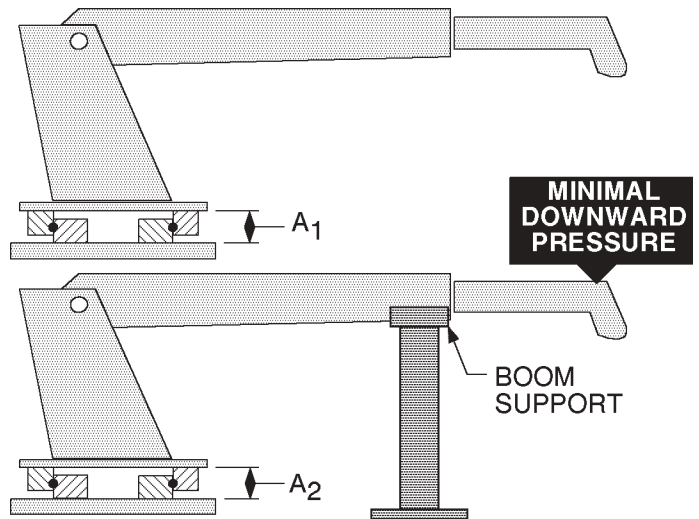

COMPARISON CHART - MODEL TO MEASURED TILT DIMENSION

NOTE	IMT CRANE, LOADER OR TIREHAND MODEL	1007 1014 1014A 1015 2015/2020 2109 3000 3816/3820 3016/3020 421/425 4300 5016/5020 6016/6020 TH7 BODY ROT'N TH1449 BODY ROT'N TH15B CLAMP TH2551B CLAMP TH2557A CLAMP	5200 5200R 5217 5800 7020 7025 7200 7415 9000 TH10 BODY ROT'N TH14 BODY ROT'N	14K160TH(Commander IV) 16000 32018 32027 32030 T30 T40	9800 12916 13031 13034 14000 15000 18000 20017 8000L H1200 H1200RR T50 TH2551B BODY ROT'N TH2557B BODY ROT'N TH2557A BODY ROT'N
THE FIGURES LISTED IN THIS CHART ARE SERVICE GUIDELINES AND DO NOT, IN THEMSELVES, REQUIRE THAT THE BEARING BE INSPECTED.					
IF THERE IS REASON TO SUSPECT AN EXCESS OF BEARING WEAR AND THE MEASURED TILT DIMENSION EXCEEDS THE DIMENSION LISTED, REMOVE THE BEARING FOR INSPECTION.					
	BALL DIA. (REF)	.875" (22mm)	1.00" (25mm)	1.18"-1.25" (30-32mm)	1.75" (44mm)
	TILT DIM. (A₁-A₂)	.060" (1.524mm)	.070" (1.778mm)	.075" (1.905mm)	.090" (2.286mm)

20000710

The information within this manual has been compiled and checked but errors do occur. To provide our customers with a method of communicating those errors we have provided the Manual Change Request form below. In addition to error reporting, you are encouraged to suggest changes or additions to the manual which would be of benefit to you. We cannot guarantee that these additions will be made but we do promise to consider them. When completing the form, please write or print clearly. Submit a copy of the completed form to the address listed below.

MANUAL CHANGE REQUEST

DATE	PRODUCT MANUAL	MANUAL PART NO.
SUBMITTED BY		
COMPANY		
ADDRESS		
CITY, STATE, ZIP		
TELEPHONE		

ERROR FOUND

LOCATION OF ERROR (page no.): _____

DESCRIPTION OF ERROR: _____

ERROR FOUND

DESCRIPTION OF ADDITION: _____

REASON FOR ADDITION: _____

MAIL TO:
IOWA MOLD TOOLING CO., INC.
BOX 189
GARNER, IA 50438-0189
ATTN: Technical Publications

IOWA MOLD TOOLING CO., INC.
BOX 189, GARNER, IA 50438-0189
TEL: 641-923-3711
TECHNICAL SUPPORT FAX: 641-923-2424
www.imt.com